

WABCO

Installation Guide

Trailer ABS with Roll Stability Support (RSS^{plus}[™]) for Constant Power Trailers with Air or Mechanical Suspensions 2S/2M or 4S/2M with Roll Stability Support (RSS) Using RSS^{plus}[™] 480 107 000 0

Before You Begin

1. Read and understand all instructions and procedures before you begin to service components.
2. Read and observe all Warning and Caution hazard alert messages in this publication. They provide information that can help prevent serious personal injury, damage to components, or both.
3. Follow your company's maintenance and service, installation, and diagnostics guidelines.
4. Use special tools when required to help avoid serious personal injury and damage to components.

Hazard Alert Definitions and Torque Symbols

WARNING

A Warning alerts you to an instruction or procedure that you must follow exactly to avoid serious personal injury and damage to components.

CAUTION

A Caution alerts you to an instruction or procedure that you must follow exactly to avoid damage to components.

 This symbol alerts you to tighten fasteners to a specified torque value.

Hazard Alert Messages

WARNING

To prevent serious eye injury, always wear safe eye protection when you perform vehicle maintenance or service.

Park the vehicle on a level surface. Block the wheels to prevent the vehicle from moving. Support the vehicle with safety stands. Do not work under a vehicle supported only by jacks. Jacks can slip and fall over. Serious personal injury and damage to components can result.

CAUTION

High voltages can damage the electronic control unit (ECU). Disconnect all connectors from the ECU before you perform any welding, electrostatic painting, or any other activity that applies high voltage to the vehicle frame. Install blind plugs into the ECU to protect the connector openings. Ground the welding or painting equipment to the part you are working on. If you are working on a moving or insulated component such as an axle, make sure it is correctly grounded through the frame. Refer to the equipment manufacturer's recommended instructions for correct procedures.

Ensure the trailer has correct electrical grounding. Refer to SAE Specification J1908.

If you require technical assistance, contact WABCO North America Customer Care at 855-228-3203. Technical publications for all WABCO products are available on our website:

www.wabco-na.com

Overview

WARNING

RSS is an advanced vehicle control system from WABCO that reduces chances of a rollover and assists the driver in maintaining control of the vehicle. However, any vehicle may overturn in some situations with or without RSS.

Having RSS^{plus}[™] does not allow drivers to take unnecessary risks. Make sure drivers do not take curves or turns faster than they would without RSS^{plus}[™] and always use safe driving techniques. Failure to do so can result in serious personal injury, damage to components, or both. An alert unimpaired driver remains the primary element in maintaining control of the vehicle and reducing the chances of rollover accidents.

WABCO's roll stability support provides an independent stability system for single, tandem or tri-axle constant-powered trailers equipped with air or mechanical suspensions. It is compatible with both disc and drum foundation brakes. The system consists of:

- An electronic control unit (ECU)/dual modulator valve assembly with built-in pressure sensors to monitor control and supply pressure, as well as axle load. A lateral accelerometer incorporated into the ECU monitors trailer stability.
- RSS*plus*™ ECU is fully serviceable with NPTF threads.
- PLC communication fully integrated
- Two or four wheel speed sensors
- J1708/1587 diagnostic cable (optional)
- External control line pressure sensor and cable (optional)
- WABCO diagnostics incorporated into WABCO TOOLBOX™ Software
- Easy-to-use blink codes
- Five generic inputs/outputs, three digital and two analog

Trailer Configurations

- This installation guide covers 2S/2M or 4S/2M trailer ABS with RSS*plus*™ installations. Sensor installation procedures are based on using ABS-prepped axles.
- RSS for 2S/1M configurations are not covered in this manual.
- RSS is permitted on B-train configurations. An RSS system is strongly advised on both trailers in this configuration, as this configuration provides maximum stability support. Contact your WABCO representative for additional information relating to pneumatic considerations for this configuration.
- Double and triple trailer applications must be pre-approved by WABCO. Application approval forms can be found under *Literature* at wabco-na.com.

Load Proportioning Function Information

All RSS*plus*™ ECUs have load proportioned default settings. Trailer braking is less aggressive when the trailer is unladen, resulting in increased brake lining life. If trailer specific load proportioning is desired, please contact WABCO North America Customer Care at 855-228-3203 for assistance. If no proportioning is desired, the unladen braking pressures may be changed with TOOLBOX™ Software. The administration of these parameters is covered in the **Parameter Entry** section.

RSS System Requirements

- A WABCO trailer in-line filter (or WABCO gladhand with integrated filter) is required for **ALL** RSS installations and is to be installed in the control line, upstream of the RSS ECU/dual modulator valve assembly.
- For correct ABS and RSS functionality, LED brake lights must be used.
- To complete the RSS*plus*™ installation, you must have 120 psi air pressure available. A 12-volt DC (10 amp minimum) power supply must also be available.
- For diagnostics or installation testing, ensure only constant power (blue pin) is applied. Do not apply power to the stoplight circuit (red pin).

NOTE: Blink codes for level one diagnostics are a standard capability for the RSS ECU. In-depth level two diagnostics are available in WABCO TOOLBOX™ Software.

RSS Definitions

These features are integrated into the RSS system.

Table A

Lateral Accelerometer	A sensing device that monitors differences in acceleration from side to side.
Control Line Pressure Sensor	A sensor that measures the control line pressure. Where trailer timing response improvement is needed, an external pressure sensor may be added.
Axle Load Pressure Sensor	A pressure sensor with a pneumatic port for the air suspension that provides load measurement for the ECU.
Supply Pressure Sensor	A sensor that monitors the trailer supply pressure and triggers a warning lamp if the pressure drops below 66 psi (4.5 bar).

RSS*plus*™ Components

ECU/Dual Modulator Valve Assembly

The valve portion of the Electronic Control Unit (ECU)/dual modulator valve assembly contains two separate modulator valves. Each valve has its own delivery ports, three per valve. Therefore, the mounting orientation — whether the valve is mounted with the sensors facing the front or the rear of the trailer — determines sensor hookup. Figure 1, Figure 2 and Figure 3.

- **Mounted with sensors facing front of trailer:** The **f** and **d** sensor connections go to the curbside and the **c** and **e** connections go to the roadside.

- **Mounted with sensors facing rear of trailer:** The **c** and **e** connections go to the curbside and the **f** and **d** sensor connections go to the roadside.

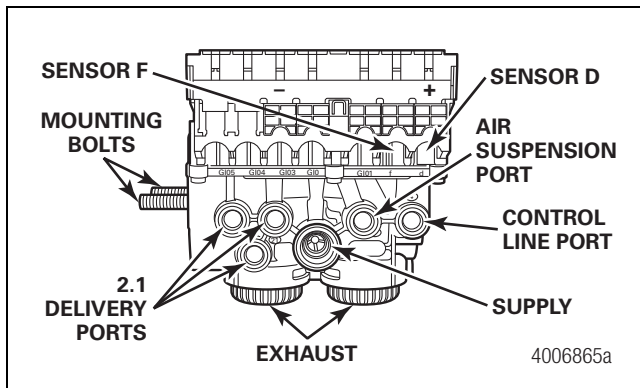

Figure 1

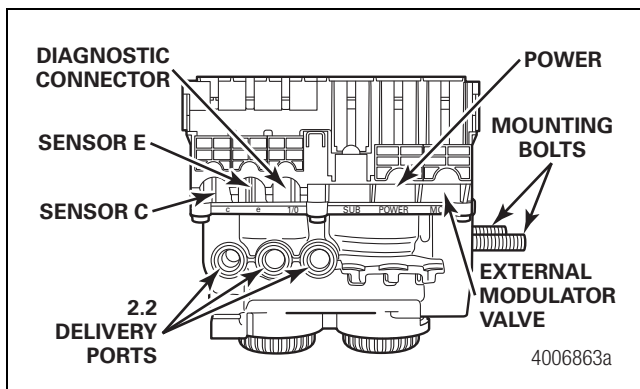

Figure 2

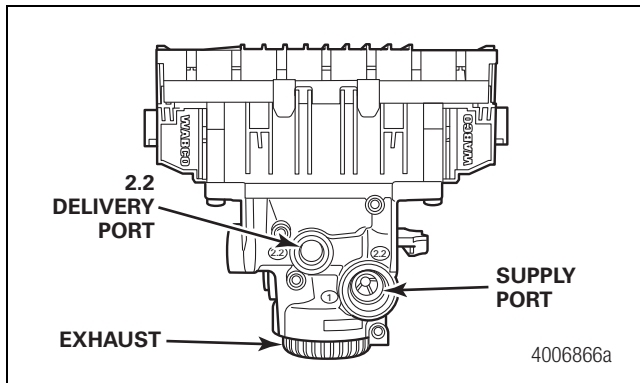

Figure 3

RSS Software

NOTE: Complete RSS software programming instructions are included in this publication.

End of line testing is required on all trailer RSS installations. Use WABCO TOOLBOX™ Software to perform this test. This software must be available at all trailer manufacturers where RSS is being installed. If you do not have this software program, please contact WABCO North America Customer Care at 855-228-3203. Do not begin the RSS installation if you do not have this software.

End of line testing must be completed before the trailer is released into service. The RSS portion of TOOLBOX™ Software is used to conduct the sign-off.

Installation

⚠ WARNING

RSS will not function if the mounting location does not meet the following specification.

Do not mount the ECU/dual modulator valve assembly facing sideways. The ECU/dual modulator valve assembly must be mounted facing the front or rear of the trailer.

⚠ CAUTION

Do not tank mount. An air tank will not support the weight of the ECU/dual modulator valve assembly and may result in damage to the air tank. A bracket may be fabricated using steel at least 3/16-inch (4 mm) thick or mounted directly to the cross member. Figure 6.

Mounting Requirements for Air Suspensions

The ECU/dual modulator valve assembly contains a lateral accelerometer that provides data for stability control. For optimum lateral accelerometer function, **the ECU must be mounted level to a rigid structure of the subframe in the center of the width of the trailer, midway between the axle spacing.** Figure 4.

NOTE: A barrier of plastic or mylar should be placed between the ECU valve assembly and the surface it will be mounted on. This will help inhibit potential corrosion between dissimilar metals.

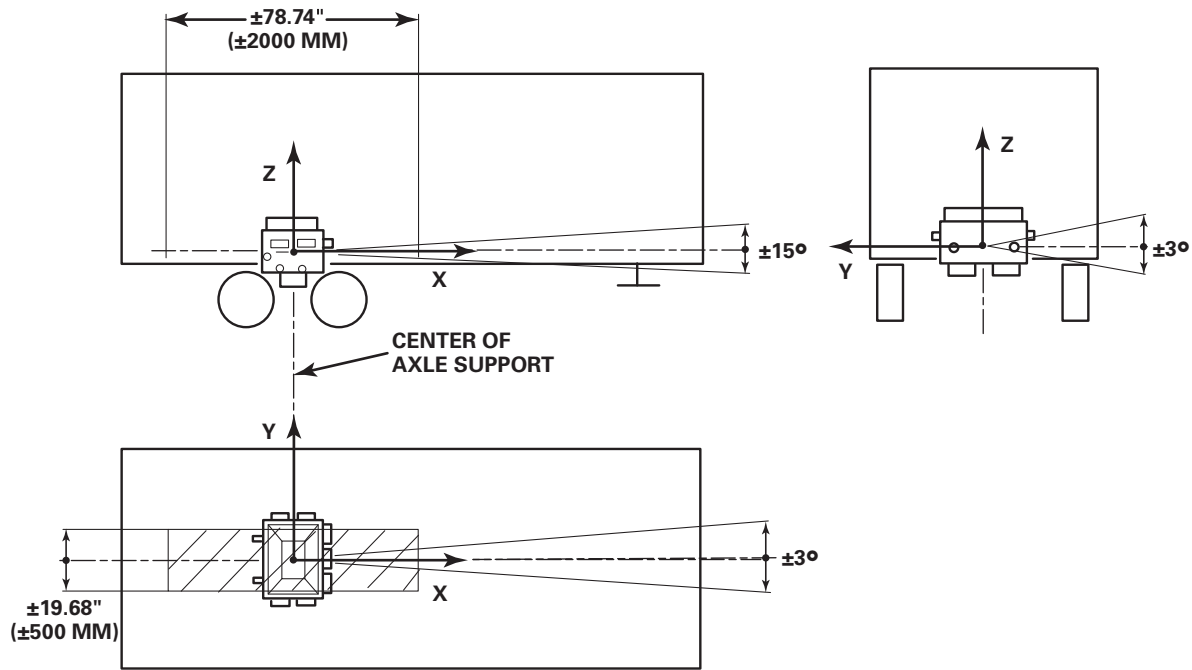

Location or Mounting Position	Permissible Maximum Deviation
Y-direction from the vehicle longitudinal axis	±19.68 Inches (±500 MM)
X-longitudinal direction from the center of the axle support	±78.74 Inches (±2000 MM)
Tilt of the ECU/dual modulator valve assembly around the X-axis (roll angle)	±3 Degrees
Tilt of the ECU/dual modulator valve assembly around the Y-axis	±15 Degrees
Rotation of the ECU/dual modulator valve assembly around the Z-axis (yaw angle)	±3 Degrees

4005548b

Figure 4

Preparation

Before beginning the installation procedure, perform the following.

- Inspect the ECU/dual modulator valve assembly for damage that may have occurred during shipping or storage.
 - Look for crushed or bent connectors.
 - Verify that the yellow retainer clips have not been bent or otherwise damaged.
 - Do not install a damaged ECU/dual modulator valve assembly. Notify your supervisor, or contact WABCO if there is any apparent damage.
- Ensure that the following installation components are available.

WABCO Components

- ECU/dual modulator valve assembly
- RSS*plus*™ power cable
- J1708/1587 diagnostic cable (optional)

- External control line pressure sensor and cable (optional)
- Sensor extension cables, two pieces for 2S systems, four pieces for 4S systems
- Sensors, two or four, for non-ABS-prepped axles
- WABCO trailer ABS in-line filter
- WABCO TOOLBOX™ Software version 12.2 or higher
- ABS indicator label, TP-95172
- Constant power label (part number 899 201 833 4)

Non-WABCO Components

- Minimum 5/8-inch O.D. nylon tubing for supply**
- 3/8-inch O.D. nylon tubing for axle load sensor
- SAE standard, DOT-approved thread sealant
- Incandescent-type DOT-approved lamp, or an LED with integral load resistor
- 1/2-inch grade 8 nuts and washers

Component Installation

ECU/Dual Modulator Valve Assembly

⚠ CAUTION

Do not tank mount. An air tank will not support the weight of the ECU/dual modulator valve assembly and may result in damage to the air tank. A bracket may be fabricated using steel at least 3/16-inch (4 mm) thick or mounted directly to the cross member. Figure 6.

RSSplus™ will not function correctly if the mounting location does not meet the following requirements.

- To complete the RSSplus™ installation, you must have 120 psi air pressure available. A 12-volt DC (10 amp minimum) power supply must also be available.
- The ECU assembly must be mounted level onto a rigid structure of the subframe and must be mounted facing either the front or the rear of the trailer.
- Mount the ECU/dual modulator valve assembly in the center width of the trailer subframe, midway between the axle spacing. Figure 4.
- Do not mount to an air tank.
- Do not mount sideways or upside down.

When mounting the ECU/dual modulator valve assembly to the trailer, refer to SAE specification J447, Prevention of Corrosion of Motor Vehicle Body and Chassis Components. Follow all recommendations and procedures. Your supervisor should have a copy of this specification or be able to tell you how to obtain one.

1. Apply SAE-standard, DOT-approved paste-type thread sealant to all NPTF threads. Do not use excessive amounts of sealant.
 - Supply ports are 3/4-inch NPTF.
 - Delivery control and air suspension ports are 3/8-inch NPTF.
2. Mount the assembly level to a rigid structure of the subframe midway between the side rails, close to the brake chambers the valve serves.
 - Drill two 1/2-inch mounting holes. The center-to-center distance between the two holes must be 2-3/4-inches (70 mm) and mount directly to a rigid structure. Figure 5.

OR

 - Build a mounting bracket with two 9/16-inch (14 mm) mounting holes with 2-3/4-inches (70 mm) center-to-center distance between the two holes. The bracket must be made of cold rolled 1040 to 1080 steel with a reinforcing gusset. Figure 6.

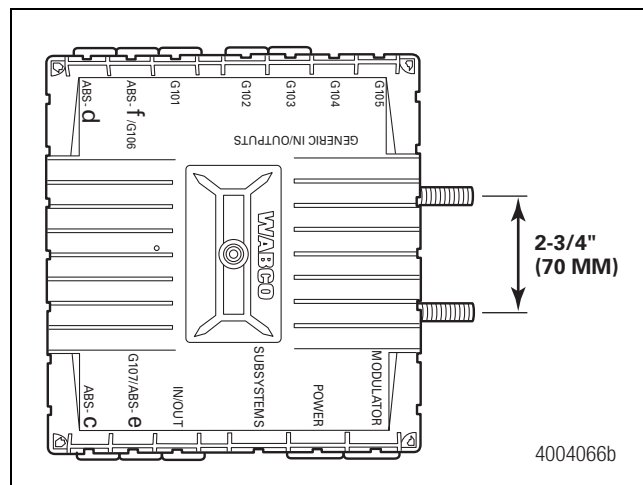

Figure 5

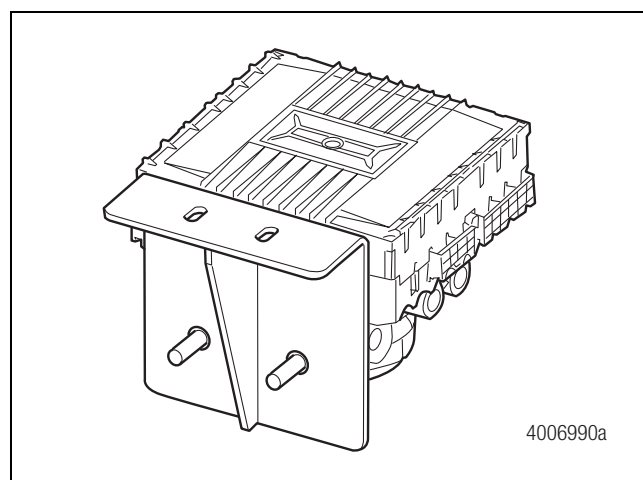

Figure 6

3. Use two 1/2-inch nuts to attach to the integral bolts. Tighten the nuts to 62 ft-lb (85 N•m).
4. For additional corrosion protection, the ECU/dual modulator assembly may be painted. Mask the exhaust ports before painting. Remove the masking after painting.
5. Washers or spring lock washers are only permitted directly under the nut.
6. The bracket or mounting area must completely cover the bearing surface of the mounting flange.

Air Lines

Before connecting the air lines, plumb the spring brake relay or emergency brake relay into the system as usual.

1. Connect the air supply line from the supply tank to the 3/4-inch NPTF supply port on the ECU/dual modulator valve assembly.
Use 5/8-inch minimum O.D. nylon tubing.

2. Connect air delivery lines to the ECU valve assembly. The ports labeled 2.1 and 2.2 are 3/8-inch NPTF. Refer to Figure 1, Figure 2 and Figure 3 for ECU valve port assignments.

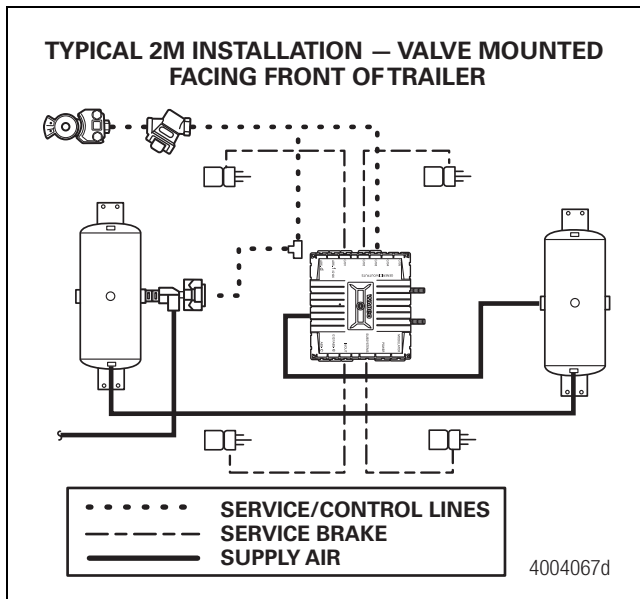

Figure 7

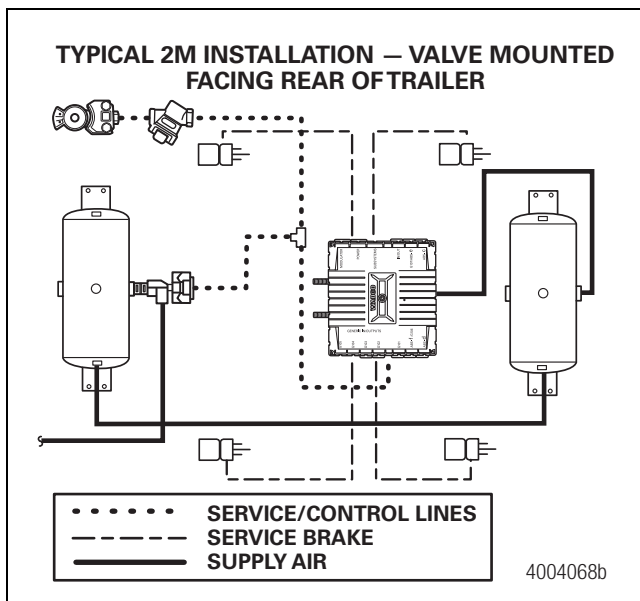

Figure 8

3. Connect the air delivery lines to the appropriate brake chambers, 3/8-inch NPTF. Refer to Figure 7 for valves mounted with sensors facing the front of the trailer and Figure 8 for valves mounted with sensors facing the rear of the trailer.

NOTE: The valve portion of the ECU/dual modulator valve assembly contains two separate valves; one dedicated to roadside wheel ends, the other dedicated to curbside wheel ends. Each valve has three delivery ports.

4. Connect the brake service or control line to the ECU/dual modulator valve's Port 4. Port 4 is 3/8-inch NPTF.
5. Connect the air bag or bellows line to Port 5 of the ECU valve assembly. Port 5 is 3/8-inch NPTF.
6. Plug any unused ports.
7. For mechanical suspensions, refer to the procedure in this guide in Mechanical Suspension Preparation.

Sensor and Sensor Extension Cables

- Do not install tooth wheels that show signs of damage such as chipped or missing teeth.
- The sensor should be installed to initially contact the tooth wheel. The center of the sensor should contact the tooth wheel near the center of the tooth width, at least 0.0035-inch (0.0889 mm) from the edge of the tooth.
- Lubricate the sensor, the sensor spring clip and the base of the sensor block using a mineral oil based lubricant containing molydisulfide with a temperature range of -40°F to 300°F (-40°C to 150°C). Lubricants approved for use on WABCO sensors and spring clips are:
 - Mobilith SHC-220 (Mobil)
 - TEK 662 (Roy Dean Products)
 - Staburags NBU 30 PTM (Kluber Lubrication)
 - Valvoline Moly-Fortified Multi-Purpose Grease
- WABCO Sensor Maintenance Wall Chart, TP-0465, is an excellent reference guide for ABS sensor maintenance. Contact WABCO North America Customer Care at 855-228-3203 to request a copy.

NOTE: WABCO recommends placing sensors on the axle that will provide the most braking performance. The suspension manufacturer can provide this information.

1. Visually inspect the tooth wheel and sensor to ensure there was no damage during shipping. Make repairs as necessary.
2. Connect the sensor and cables on the prepped axles to the sensor extension cables. Verify that each connection is secure. Figure 9.

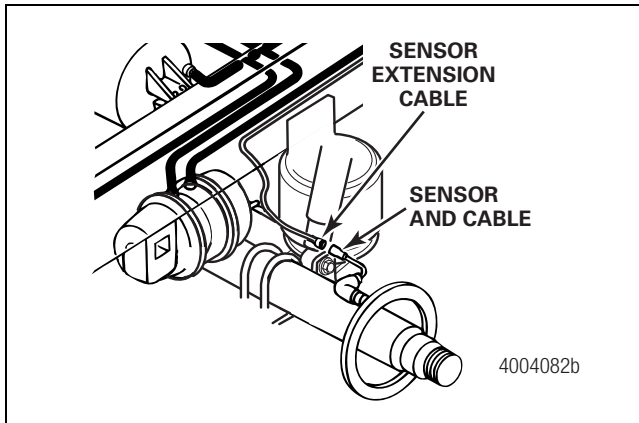

Figure 9

3. Route the sensor cable along the back side of the trailer axle and up the brake hose to the ECU/dual modulator valve assembly.

⚠ CAUTION

Do not overtighten the tie wraps on a cable. Overtightening can damage the cable. Do not tie wrap the molded sensor plug. The sensor extension cable must follow the brake hose to the ECU/dual modulator valve assembly to allow for axle jounce and rebound.

4. Secure every eight inches (203 mm) with tie wraps or cable clips.
5. Pull the sensor retainer clip on the ECU/dual modulator valve assembly OUT.
6. Plug the sensor extension cables into the ECU/dual modulator valve assembly. To secure the connection, push the sensor retainer clip IN. Connect the sensors.

ECU/Dual Modulator Valve Assembly Mounted with the Sensors Facing the Front of the Trailer

NOTE: If a lift axle is sensed with a 4S/2M installation, sensors **e** and **f** must always be used on the lift axle to avoid an unwanted ABS indicator lamp illumination. These are the default settings and may be changed.

- 2S/2M (Figure 16 and Figure 18)
 - Connect the curbside sensor at **d**.
 - Connect the roadside sensor at **c**.
- 4S/2M Tandem Axle (Figure 20)
 - Connect the curbside front sensor at **d**.
 - Connect the curbside rear sensor at **f**.
 - Connect the roadside front sensor at **c**.
 - Connect the roadside rear sensor at **e**.

- 4S/2M Tri-Axle (Figure 22)
 - Connect the curbside front sensor at **d**.
 - Connect the curbside rear sensor at **f**.
 - Connect the roadside front sensor at **c**.
 - Connect the roadside rear sensor at **e**.

ECU/Dual Modulator Valve Assembly Mounted with the Sensors Facing the Rear of the Trailer

NOTE: If a lift axle is sensed with a 4S/2M installation, sensors **e** and **f** must always be used on the lift axle to avoid an unwanted ABS indicator lamp illumination. These are the default settings and may be changed.

- 2S/2M (Figure 17 and Figure 19)
 - Connect the curbside sensor at **c**.
 - Connect the roadside sensor at **d**.
 - 4S/2M Tandem Axle (Figure 21)
 - Connect the curbside front sensor at **c**.
 - Connect the curbside rear sensor at **e**.
 - Connect the roadside front sensor at **d**.
 - Connect the roadside rear sensor at **f**.
 - 4S/2M Tri-Axle (Figure 23)
 - Connect the curbside front sensor at **c**.
 - Connect the curbside rear sensor at **e**.
 - Connect the roadside front sensor at **d**.
 - Connect the roadside rear sensor at **f**.
7. Create a strain relief to protect the sensor extension cables. Without this strain relief, normal trailer jounce and vibration will cause the terminals to spread and loosen. Use a tie wrap or clip to secure the cable to the air hose delivery lines. Figure 10.

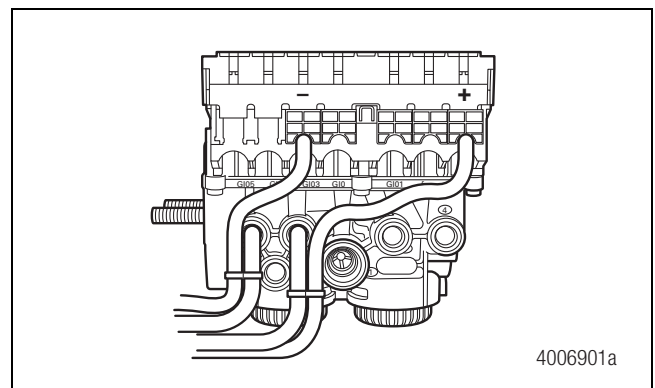

Figure 10

8. Bundle any excess cable into a bow tie. Figure 11.

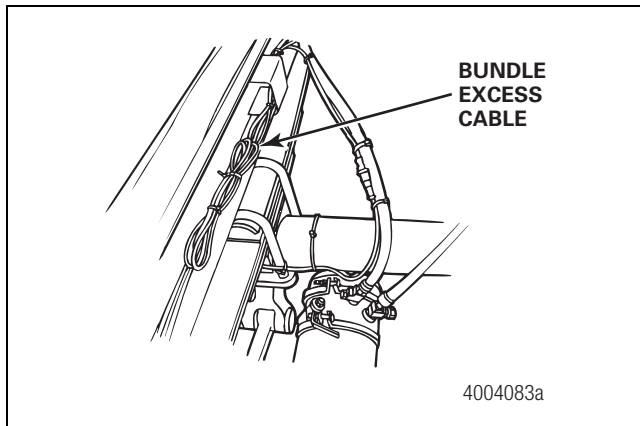

Figure 11

NOTE: Various cable lengths are available.

9. Secure the excess cable in the subframe of the vehicle or along the air hoses as appropriate. Excess cable should not exceed two feet (609 mm).

Lift Axle

- A lift axle may be specified on any ABS sensed axle.
- Sensors **e** and **f** must be used on the sensed, liftable axle.

RSS Power Cable

1. Select a location to run the cable on a frame rail or cross member.
2. Verify that the cable is long enough to reach the ABS dropout for the main trailer harness from the ECU.
3. Attach the WABCO connector to the ECU/dual modulator assembly.
 - A. Pull the power connector retainer clip OUT and remove the protective cap from the ECU/dual modulator valve assembly.
 - B. Plug the WABCO connector on the RSS power cable into the ECU power connector.
 - C. Push the power connector retainer clip on the ECU/dual modulator valve assembly IN to securely lock in place.

NOTE: If you are routing this cable to a junction box, or if it is necessary to cut the cable, please contact WABCO North America Customer Care at 855-228-3203 for assistance. Refer to the pinout information in Figure 12 for additional cable information.

4. Route the end of the cable with the five-pin Weather Pack connector to the ABS dropout of the main trailer harness.

NOTE: Leave enough slack in the cable to compensate for flexing of the trailer and subframe.

5. Secure the cable correctly in the subframe to prevent cable damage.
6. Bundle any excess cable into a bow tie. Figure 11.
7. Plug the five-pin Weather Pack connector into the ABS dropout of the mating receptacle on the main trailer harness. Figure 12.

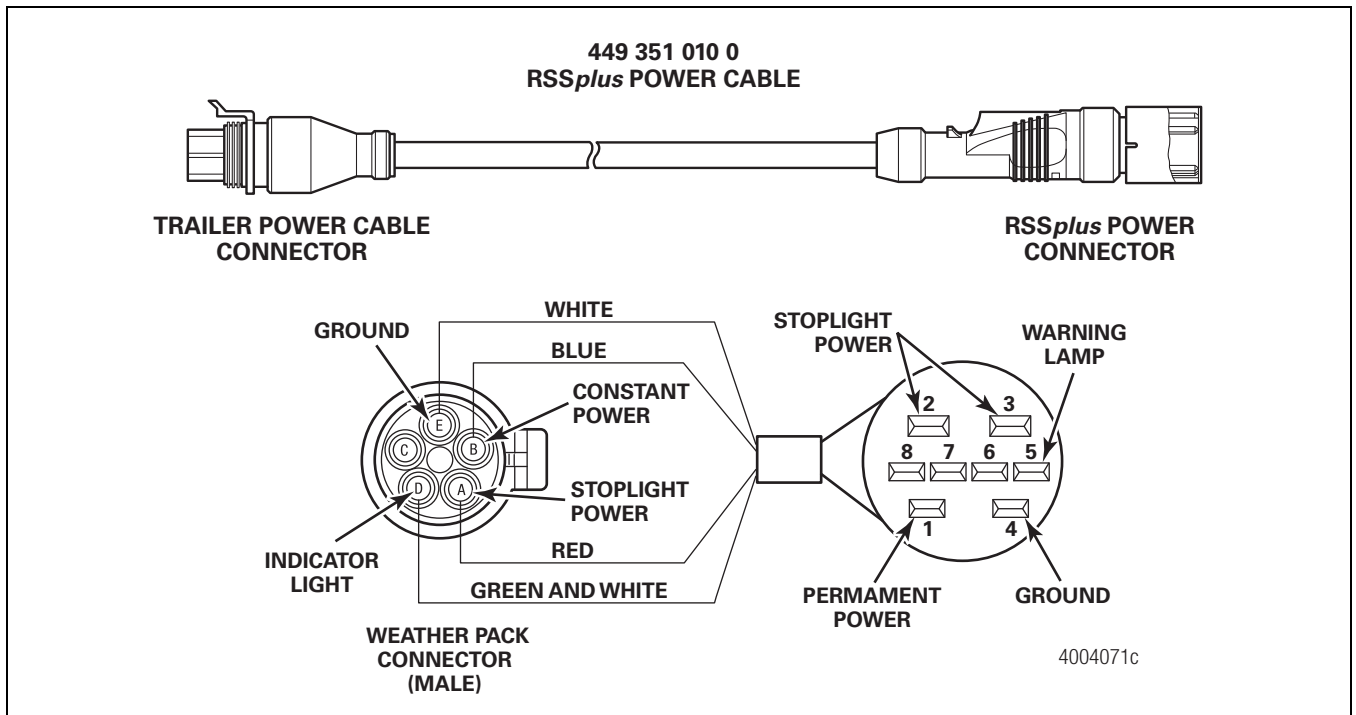

Figure 12

Optional J1708/1587 Diagnostic Cable

NOTE: Leave enough slack in the cable to compensate for flexing of the trailer and subframe.

1. Pull the diagnostic connector (labelled in/out on the ECU valve) retainer clip OUT and remove the protective cap from the ECU/dual modulator valve assembly.
2. Plug the connector on the diagnostic cable into the ECU/dual modulator valve assembly.
3. Push the hinged connector retainer clip on the ECU/dual modulator valve assembly IN to securely lock in place.
4. Install the diagnostic connector so that the diagnostic plug is accessible. The normal location is on the right front corner of the subframe, but will vary depending on the type of trailer.
5. Secure the cable correctly in the subframe to prevent cable damage.

NOTE: Leave enough slack in the cable to compensate for flexing of the trailer and subframe.

6. Bundle any excess cable into a bow tie and secure the cable in the subframe. Figure 11.

Trailer ABS Indicator Lamp

Refer to the vehicle specification sheet for the recommended mounting location of the indicator lamp.

- Use a DOT-approved lamp with ABS etched on the lens. These lamps are available from major trailer parts suppliers.
- To ensure correct lamp operation, use an incandescent-type DOT-approved lamp or an LED with integrated load resistor.

Control Line Pressure Sensor (Not Used in All Installations)

NOTE: The control line pressure sensor is used for special trailer applications.

If the control line pressure sensor is to be installed to help improve timing, you will need a control line pressure sensor and cable. Figure 13.

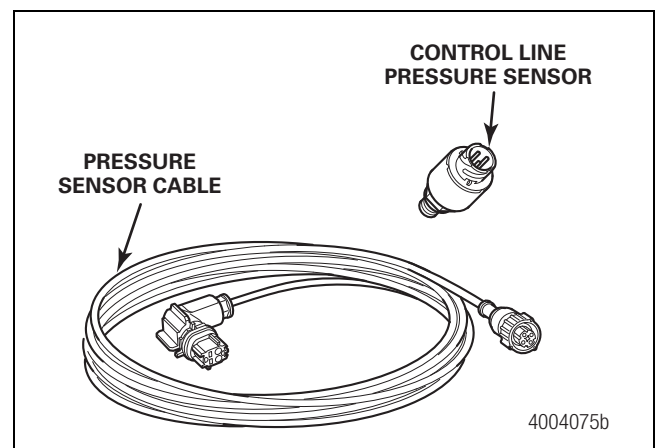

Figure 13

1. Install a T-fitting between the gladhand and the control line. Then, screw the control line pressure sensor into the T-fitting in the control line.
2. Attach the pressure sensor connector to the pressure sensor.
 - A. Route the pressure sensor cable from the pressure sensor to the ECU and secure the cable to prevent any damage. Bundle any excess cable into a loop or bow tie and secure the excess cable in the subframe of the vehicle.
 - B. Plug the cable connector into the IN/OUT connector at the side of the ECU.

Trailer ABS In-Line Filter Valve

Install the WABCO in-line filter valve in the control line, upstream of the RSS ECU/dual modulator valve assembly. Figure 14.

- The in-line filter valve must be installed with the filter portion facing DOWNWARD so that the air line ports are horizontal. Figure 15.
- Allow sufficient clearance for servicing the valve. A minimum of 3.5-inches (90 mm) to release the retainer slide bar and a minimum of two-inches (50 mm) to allow for the removal and installation of the internal components is required. Figure 15.
- Port Fittings: 1/2-inch NPTF. Port 1 is supply from the tractor, Port 2 is delivery to the trailer.
- The in-line filter valve must be rigidly supported (e.g., nipple mounted to gladhand or supported by a bracket and clamp).
- Refer to Technical Bulletin TP-03100, Trailer ABS In-Line Filter Valve, for service information covering the in-line filter valve.

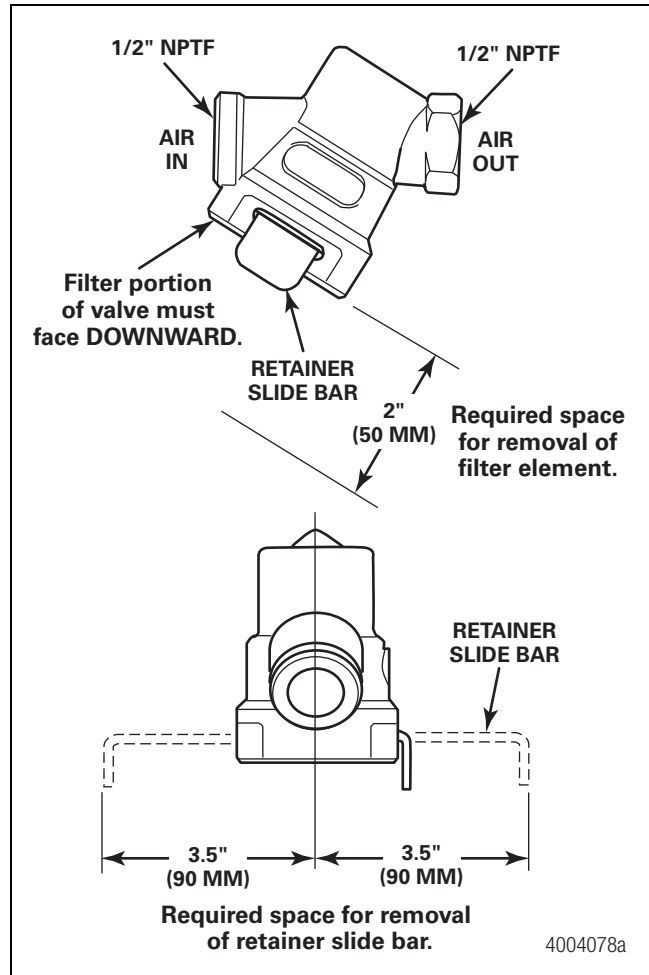

Figure 15

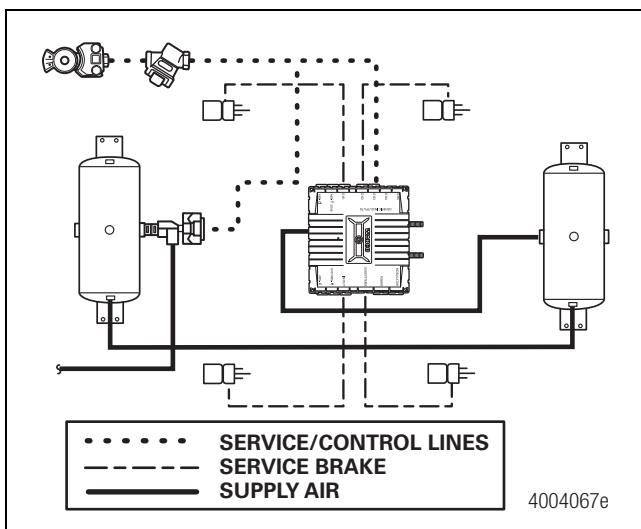

Figure 14

System Layouts

NOTE: WABCO recommends placing sensors on the axle that will provide the most braking performance. The suspension manufacturer can provide this information.

Typical trailer RSS layouts are illustrated in Figure 16 through Figure 24.

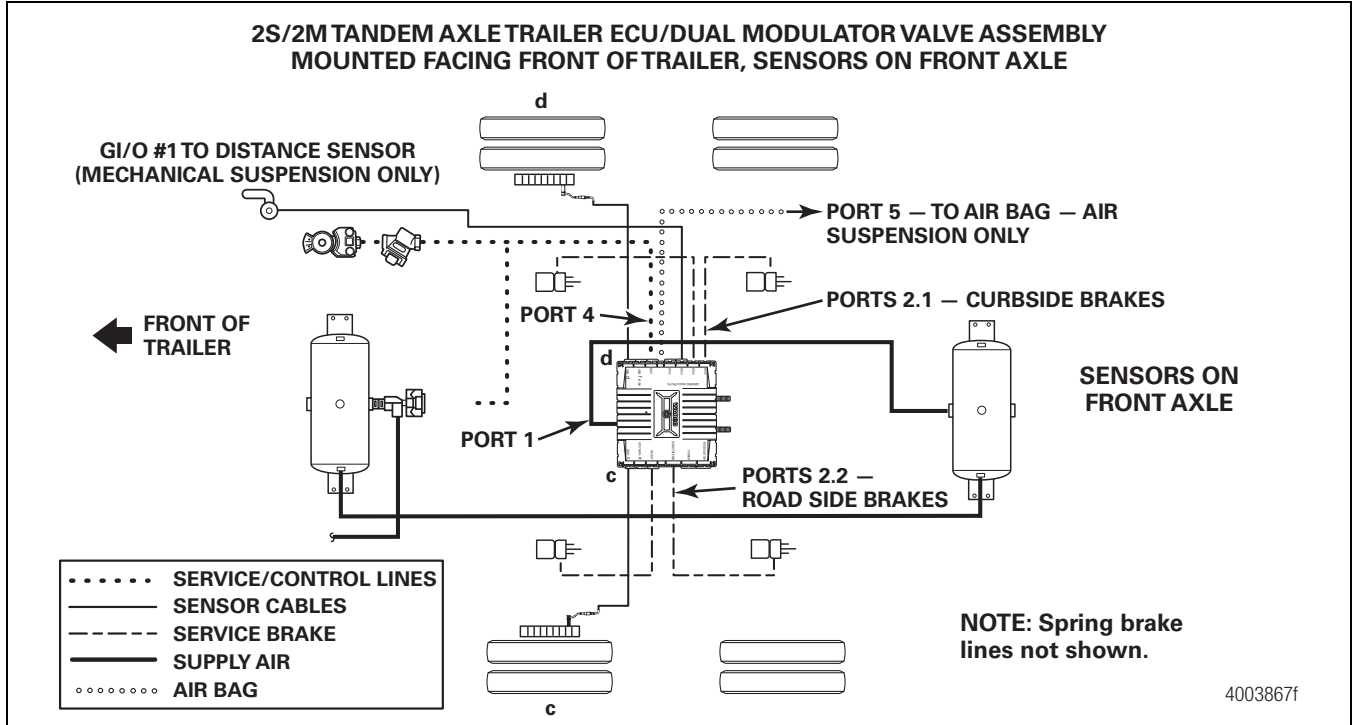

Figure 16

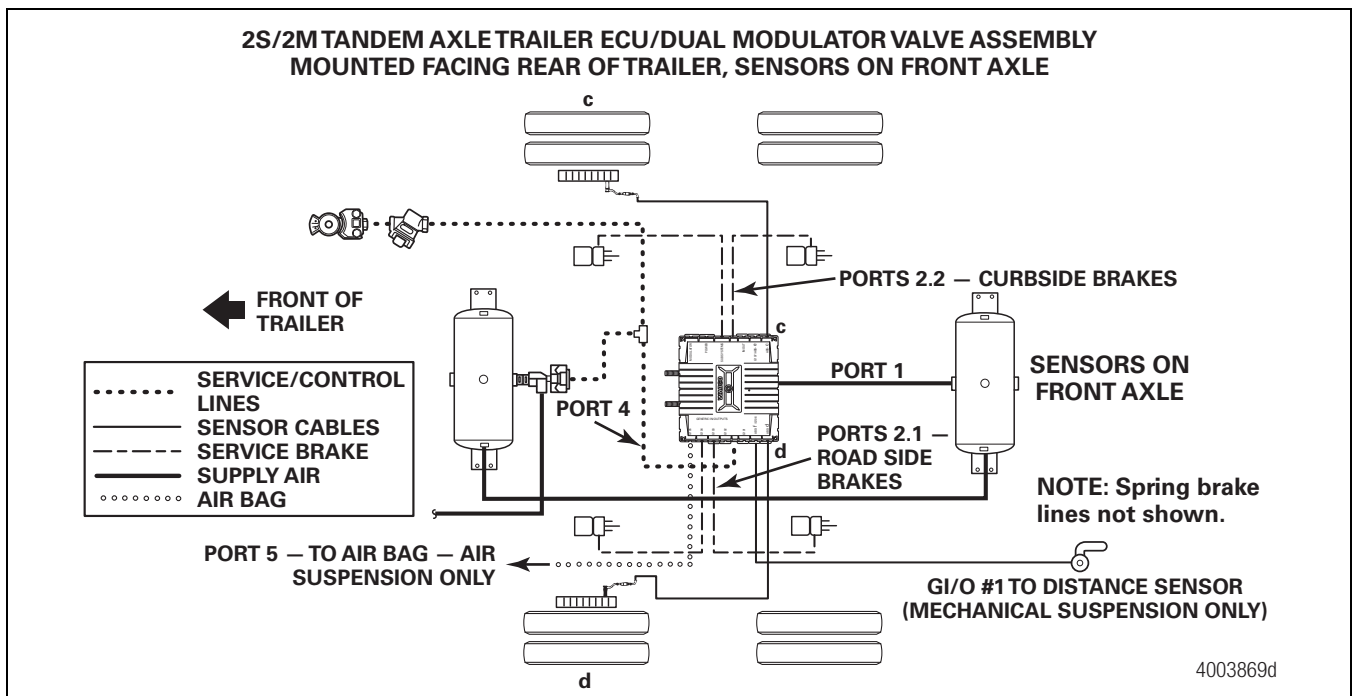

Figure 17

**2S/2M TANDEM AXLE TRAILER ECU/DUAL MODULATOR VALVE ASSEMBLY
MOUNTED FACING FRONT OF TRAILER, SENSORS ON REAR AXLE**

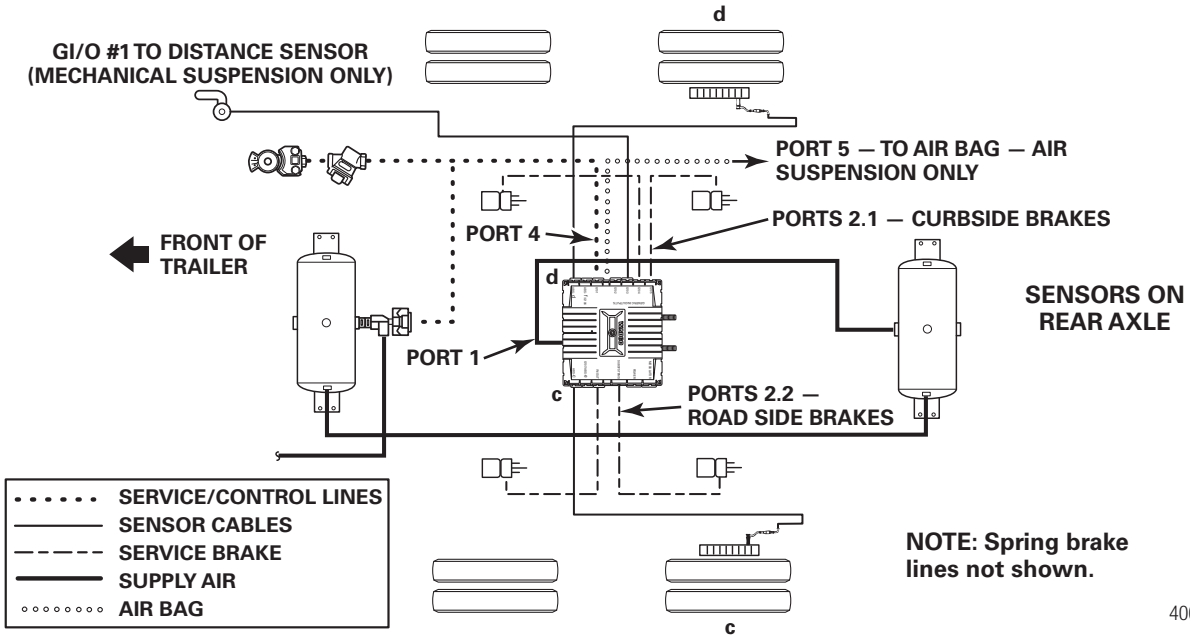

Figure 18

**2S/2M TANDEM AXLE TRAILER ECU/DUAL MODULATOR VALVE ASSEMBLY
MOUNTED FACING REAR OF TRAILER, SENSORS ON REAR AXLE**

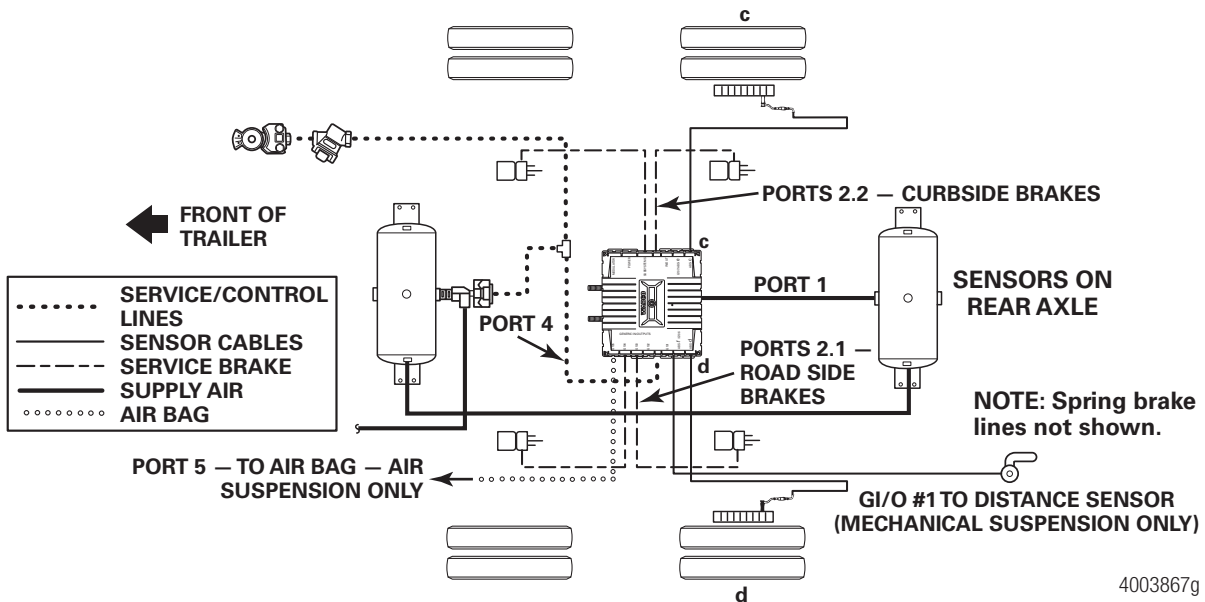

Figure 19

**4S/2M TANDEM AXLE TRAILER ECU/DUAL MODULATOR VALVE ASSEMBLY
MOUNTED FACING FRONT OF TRAILER**

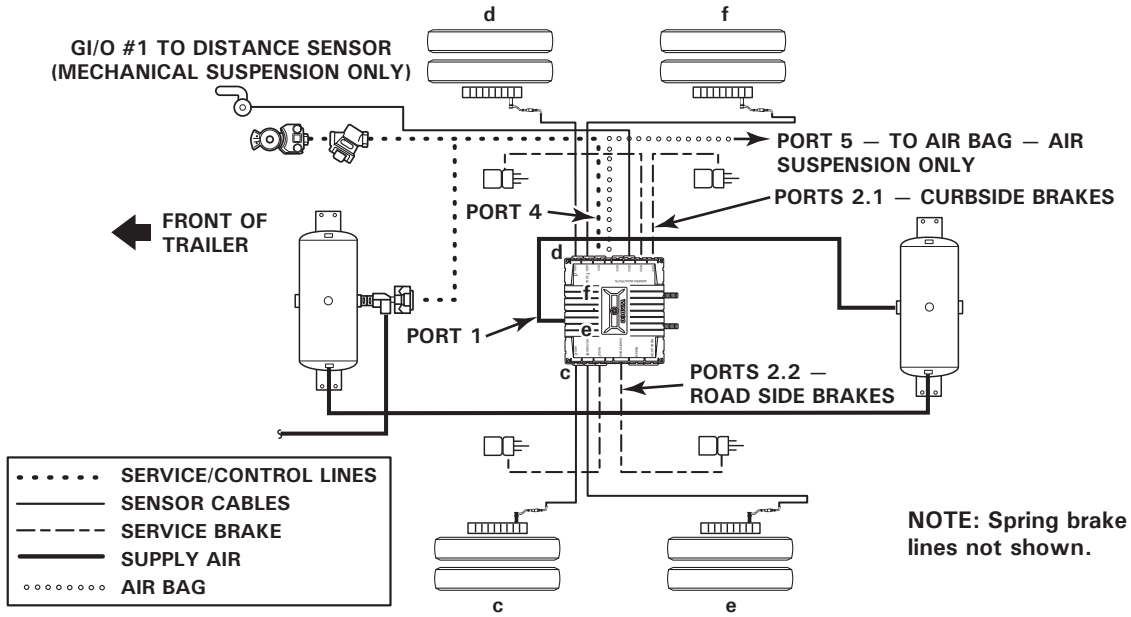

Figure 20

**4S/2M TANDEM AXLE TRAILER ECU/DUAL MODULATOR VALVE ASSEMBLY
MOUNTED FACING REAR OF TRAILER**

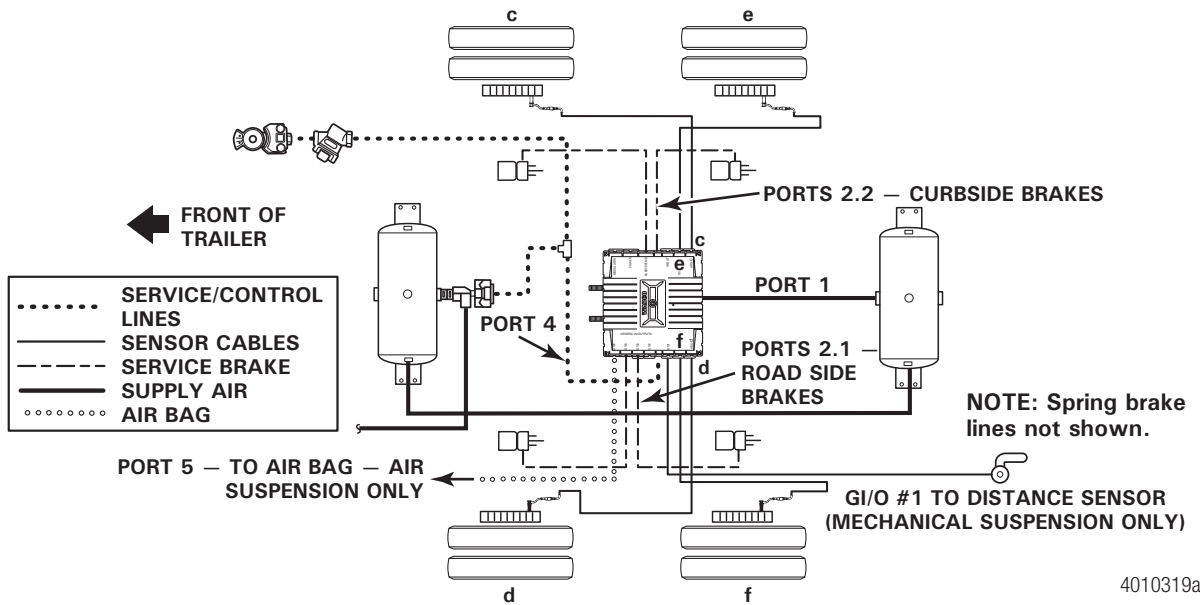

Figure 21

**4S/2M TRI-AXLE TRAILER ECU/DUAL MODULATOR VALVE ASSEMBLY
MOUNTED FACING FRONT OF TRAILER**

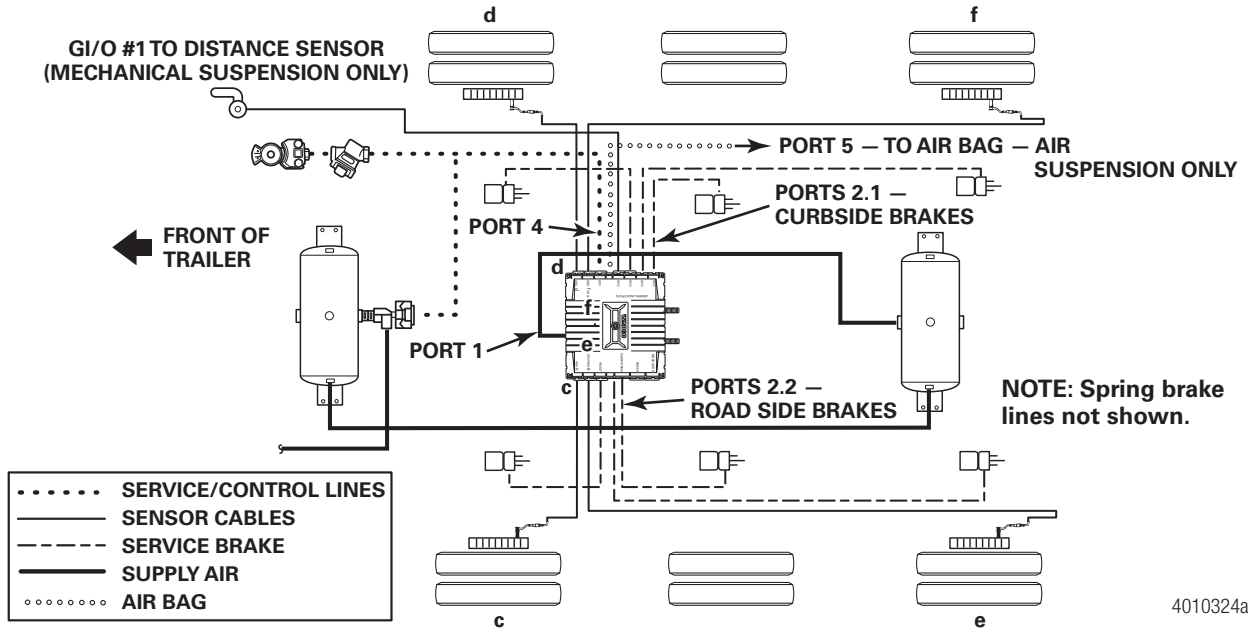

Figure 22

**4S/2M TRI AXLE TRAILER ECU/DUAL MODULATOR VALVE ASSEMBLY
MOUNTED FACING REAR OF TRAILER**

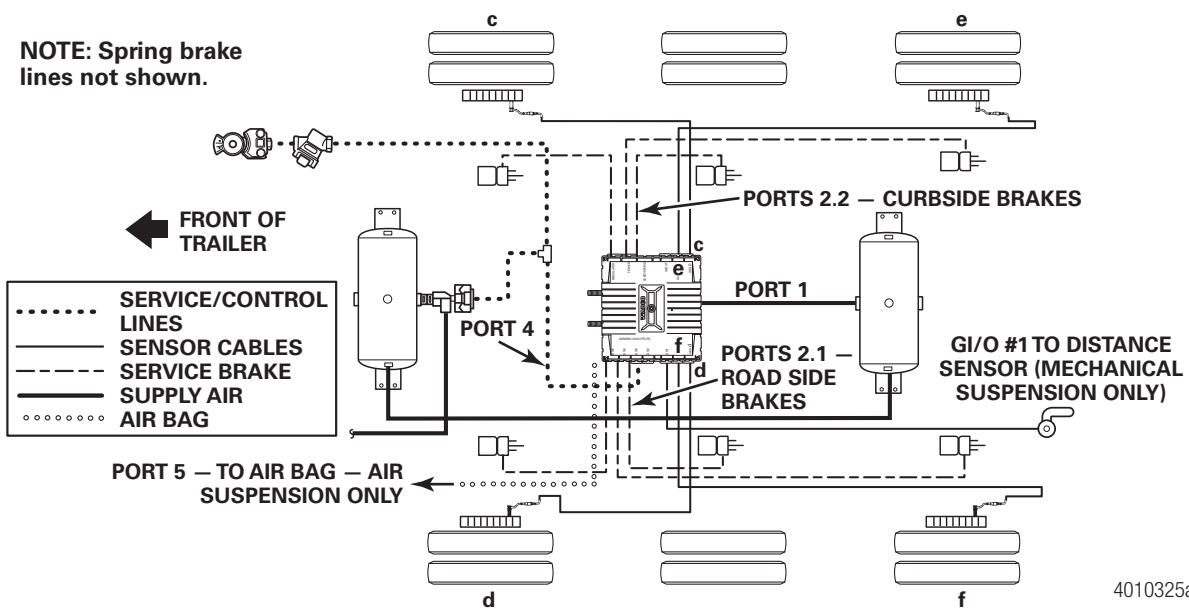

Figure 23

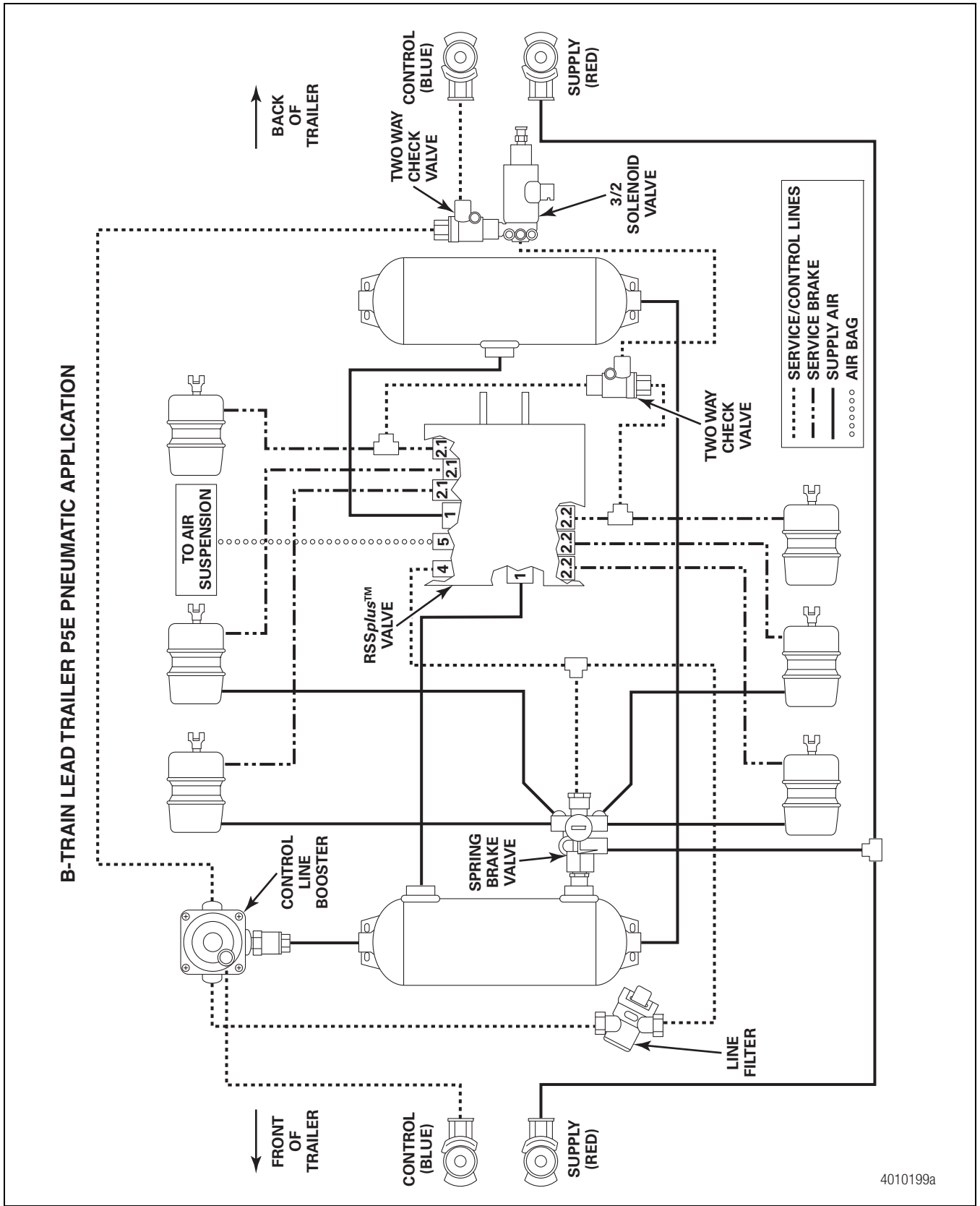

Figure 24

Multiple Trailer Applications

Specific multiple trailer applications require additional plumbing and TOOLBOX™ Software configuration. Not all multiple trailer configurations have been approved. Application approval forms can be found under *Literature* at wabco-na.com.

P5E

The Roll Stability System can be configured on B-Train trailers through the use of the patented WABCO P5E pneumatic application. The P5E system ensures that uniform braking occurs on both lead and pup trailers at the same time, similar to standard braking. The RSS_{plus}™ valve and the P5E are required on the lead trailer of a B-Train, and it is required that an RSS_{plus}™ valve be installed on the pup trailer as well. Additional valves are required as illustrated in Figure 24. The P5E kit for RSS_{plus}™ is part number 400 850 057 2.

The ATC - Generic I/O Cable, part number 449 443 030 0, is connected to the GIO 3 port on the RSS+ ECU and on the electronics connector of the 3/2 Solenoid Valve, part number 472 170 997 0. The air system plumbing diagram that integrates the 3/2 Solenoid Valve and Two Way Check Valve, part number 934 099 025 0, is illustrated in Figure 24. To maximize air system timing, both Two Way Check Valves used in the P5E application should have the two inlet ports oriented so that they are perpendicular to the ground. The inlet port on the integrated valve that is fed from the Control Line Booster should be oriented upward.

Once the hardware has been installed, TOOLBOX™ Software parameters must be configured to activate the P5E system. When programming the ECU, ensure that “Level 2 RSS Activation Output (GIO 3)” is selected. Figure 25. Refer to the Parameter Entry section for setting the vehicle parameters.

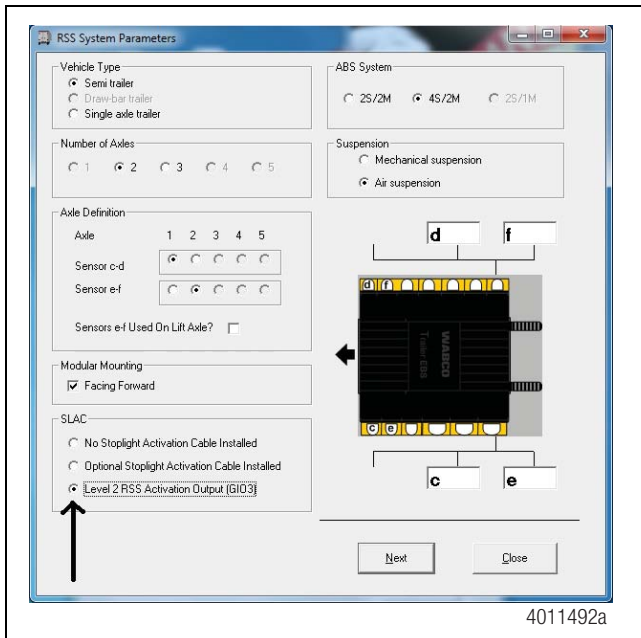

Figure 25

After the P5E has been installed and the parameters have been saved to the ECU, the End of Line system sign-off must be performed. Refer to the System Sign-Off (End of Line Testing) section for End of Line testing. Once the End of Line testing is complete and the P5E is ready for testing, proceed to the Tests pull-down menu and select Level 2 Function. Figure 26.

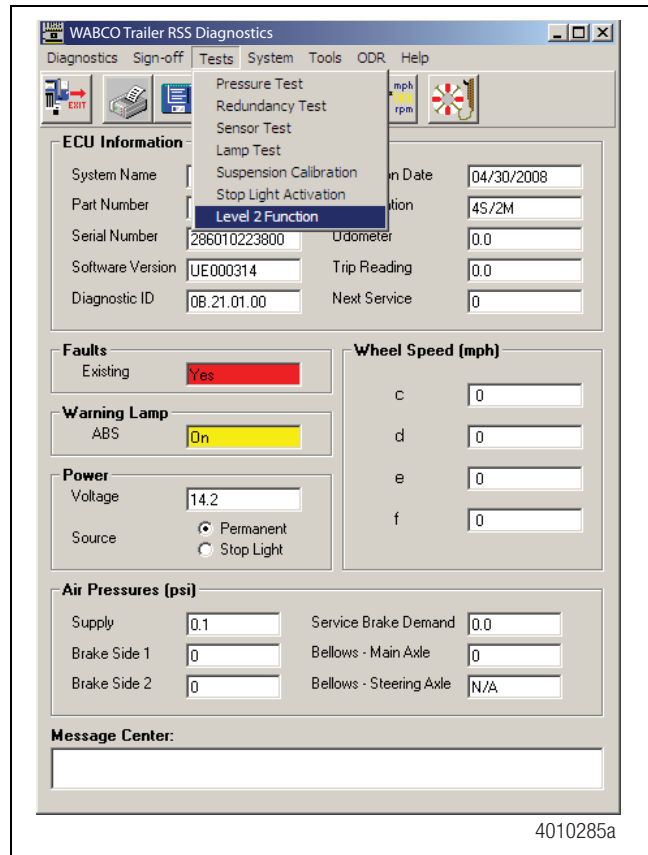

Figure 26

Press the Start Test button. Figure 27.

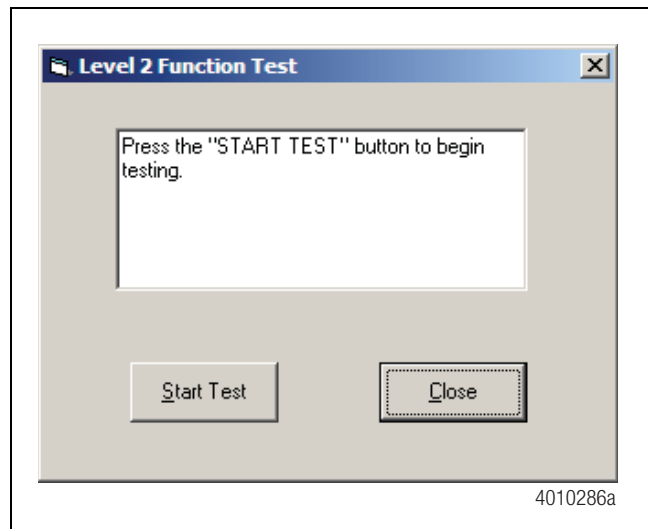

Figure 27

During the sign-off procedure, this message will appear asking the technician to monitor the pressure gauge at the rear gladhand to confirm the RSS system is applying 50 psi (3.45 bar). This test validates that the pneumatic and electrical connections are correct. Figure 28.

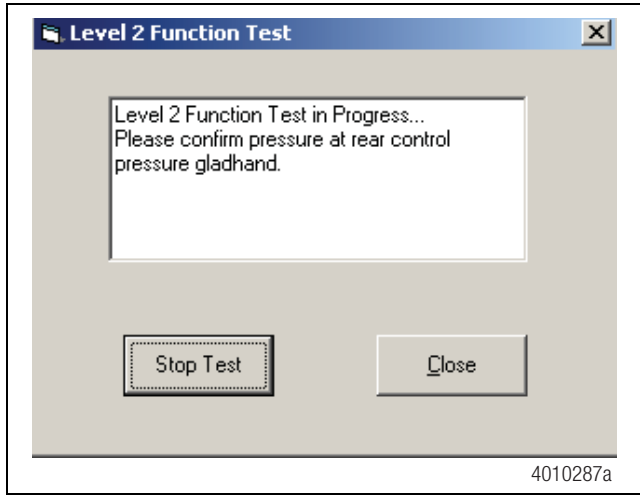

Figure 28

Once confirmed that the rear gladhand is maintaining 50 psi (3.45 bar), click the Close button. If 50 psi \pm 5 psi (3.45 \pm 0.345 bar) is not present, click the Stop Test button, exit the Level 2 test and make the appropriate repairs.

Mechanical Suspension Preparation

Installation of the RSS system on a mechanical suspension is similar to the installation on an air suspension with the following differences:

- A. Port 5, labeled 'air suspension port' in Figure 1, MUST be plugged.
- B. The WABCO Distance Sensor must be attached to the trailer structure directly above the axle, close to the axle's center. Figure 30.
- C. Insert the Distance Sensor Cable into GI/O #1 on the RSS ECU and connect it to the Distance Sensor. Figure 29.

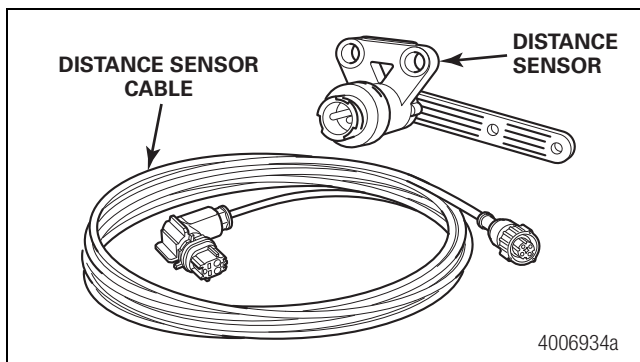

Figure 29

Mechanical Suspension Installation

The Distance Sensor is mounted to the cross member above the axle. Figure 30. It must be mounted directly to the trailer structure. If needed, a steel bracket may be fabricated and then welded to the cross member, in order to bring the Distance Sensor to the appropriate mounting height. The distance sensor should be mounted close to the center of the trailer.

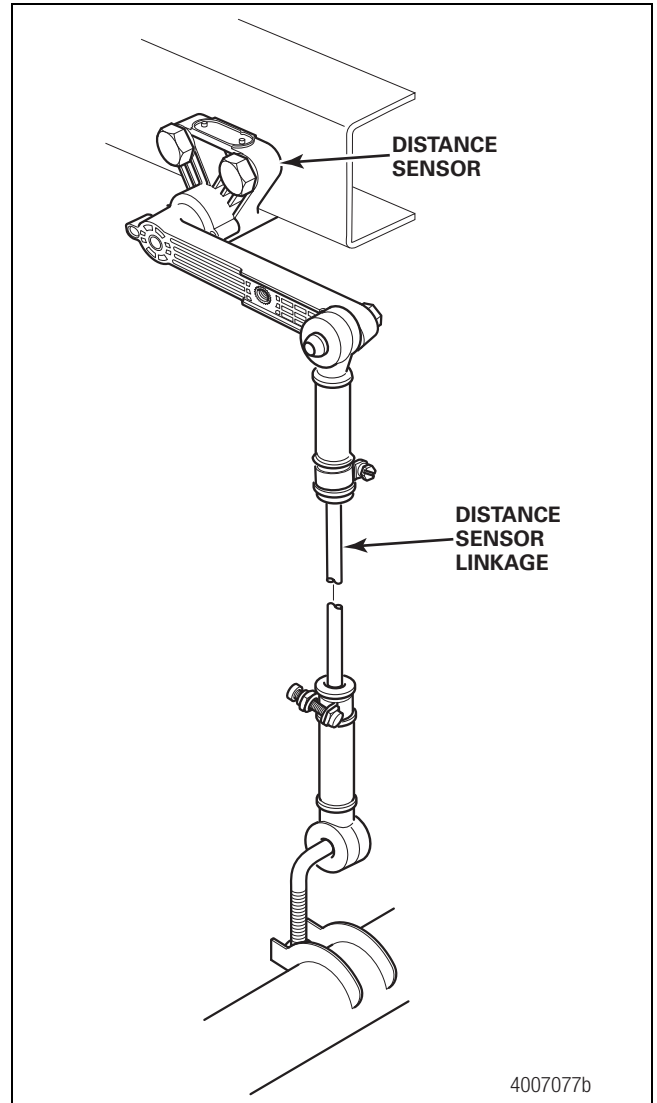

Figure 30

The Distance Sensor Linkage must be attached to the axle with a standard leveling valve axle clamp, heavy-duty band clamp, or to a fabricated bracket that is welded to the axle.

The Distance Sensor must be mounted so that the sensor arm is parallel to the ground when the trailer is unladen (empty). This allows the Distance Sensor to be correctly calibrated with the *RSSplus™* software. When installing the Distance Sensor, a small roll pin must be temporarily installed to keep the Distance Sensor arm from moving. Remove this pin after installation and before the End of Line test. Figure 31.

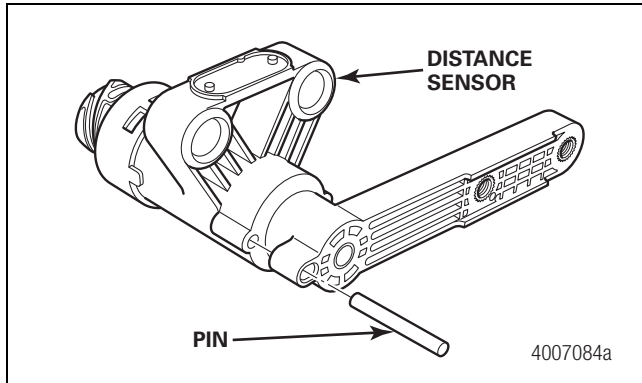

Figure 31

The rod that connects the Distance Sensor Lever to the Distance Sensor Linkage, WABCO part number 105 100 002 0, is provided by the trailer OEM. This metal rod needs to be 3/16-inch (6 mm) in diameter.

Refer to Figure 32 for the correct installation of the Distance Sensor and its components.

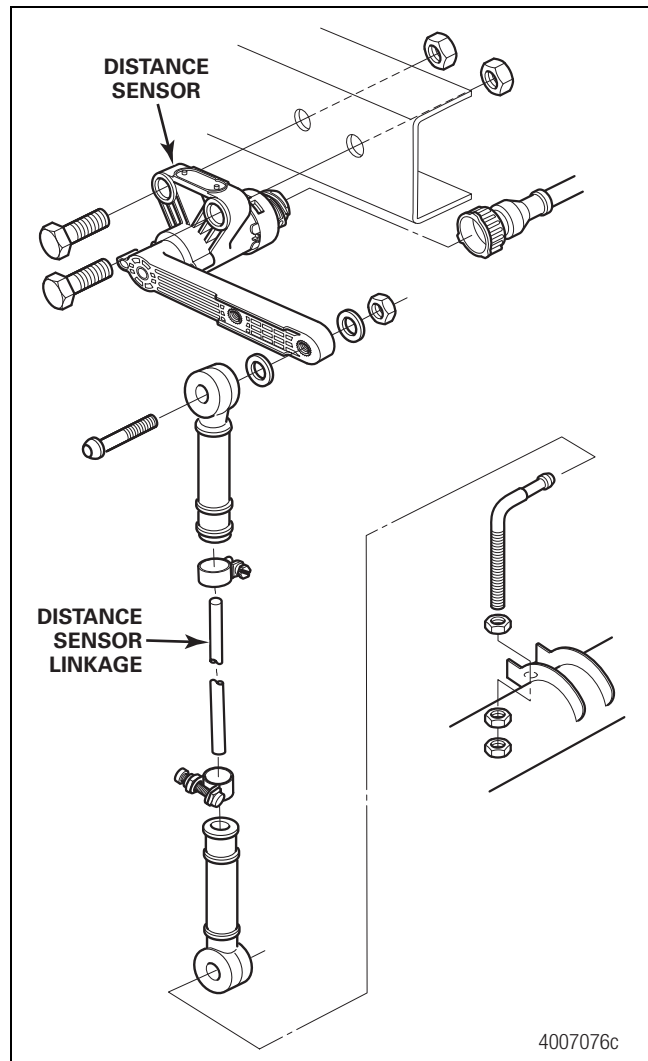

Figure 32

Distance Sensor Extension Lever

Some trailers experience jounce due to certain spring suspensions' characteristics and require an extension of the distance sensor. This extension lever (part number 441 901 715 4) allows the lever length parameter in the *TOOLBOX™* Software to be set to 150 mm. Mounting hardware for the extension lever is found in the linkage kit (part number 105 100 002 0). Figure 33.

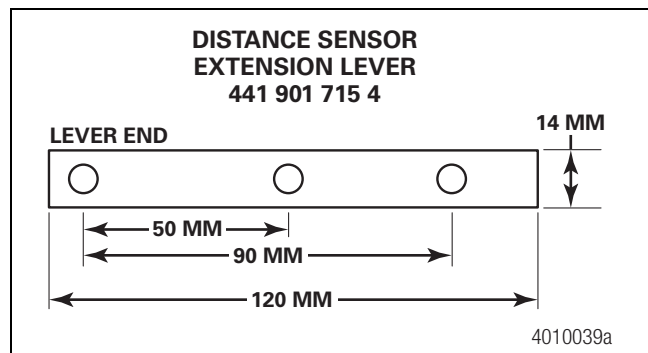

Figure 33

Interaxle Rod

If the variation in saddle height exceeds the calculated limits, it is necessary to compensate for this effect by using an interaxle rod to connect the sensor to the axles. This interaxle rod has to be connected to both axles via rubber elements, installation may change due to spring attachment method used by suspension supplier. Figure 34.

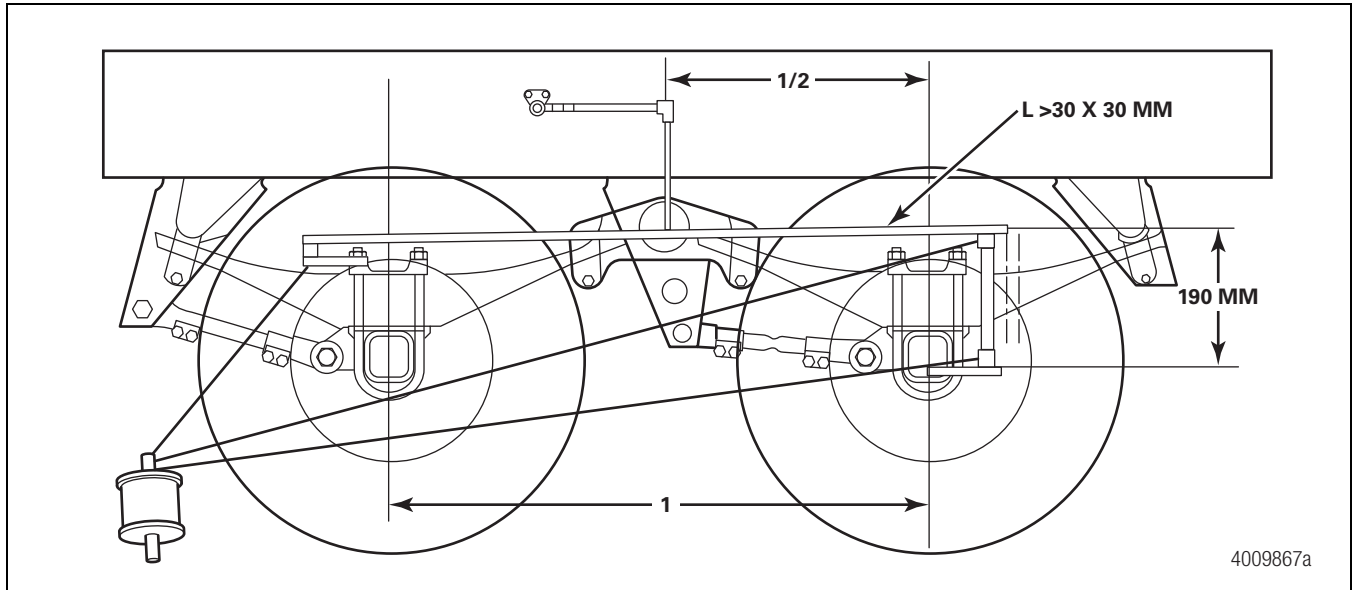

Figure 34

The distance sensor has to be connected at half of the distance between both axles using the rod with a coupling piece, part number 433 401 033 0. The rod, which will be provided by the trailer manufacturer, must have an L-profile of at least 30 x 30 mm or a tube with at least a 25 mm diameter. Figure 35.

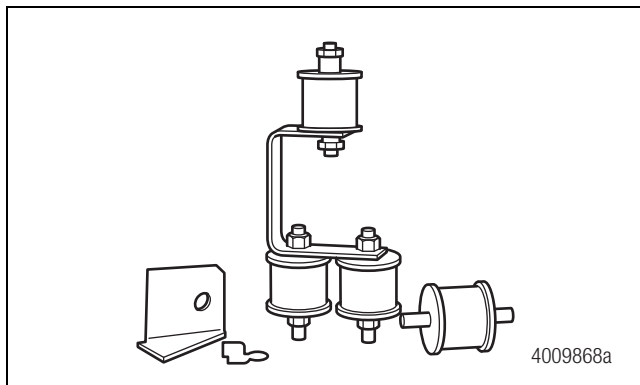

Figure 35

Distance Sensor Applications for Trailers with Mechanical Suspension

Calibration and Restrictions

Single-Axle Semi Trailer

No special precautions must be taken into account. The calibration of single axle trailers has to be performed according to the calibration instructions that follow.

Two-Axle Semi Trailer

Two-axle trailers with mechanical suspension deflection values can be affected by the tractor fifth wheel height variance. A change in this value from the calibrated value can affect the performance of the RSS interventions. Figure 36.

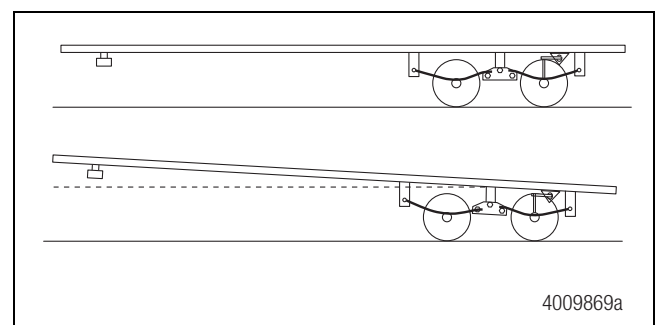

Figure 36

Fifth Wheel Height Variation Restrictions

To minimize the effect of variation in fifth wheel height that might occur during operation, the following conditions need to be satisfied:

- Installation of the distance sensor on the rear axle
- Calibration to be performed with the lowest fifth wheel height which may occur during operation.

This procedure will minimize the load measurement error caused by any increase of fifth wheel height from the calibration height. The following diagram (Figure 37) shows the limitations for the admissible increase of the fifth wheel height:

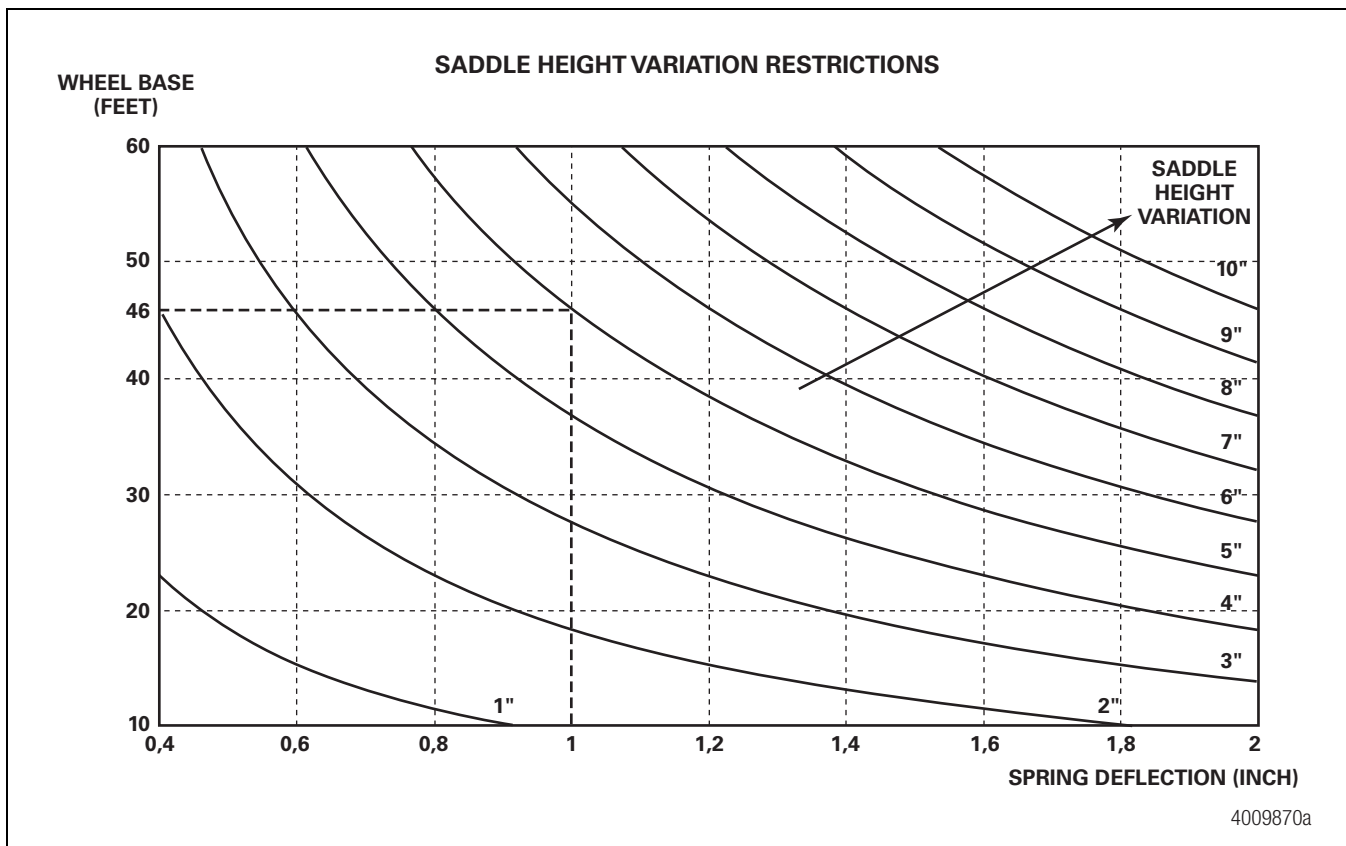

Figure 37

The engineering-generated diagram reflects the relationship between vehicle wheel base, spring deflection and admissible variation of fifth wheel height. Wheel base means the distance between king pin and middle of the bogie. Deflection means the maximum deflection between laden and unladen status.

Example:

For a vehicle with a wheel base of 46 ft and a suspension deflection of 1 inch, a variation of fifth wheel height of 5 inches is acceptable (e.g. if vehicle was calibrated at 45 inches initially, the saddle height may vary between 45 inches and 50 inches).

NOTE:

- In case of slider bogies, the shortest possible wheel base is to be considered
- In case of bogies with wide spread axles (rocker length bigger than 20 inches), the admissible range of saddle height variation is reduced by 30%
- If the distance sensor needs to be installed on the front axle, please contact WABCO for assistance

NOTE: A label is to be affixed to the trailer showing parameter settings, used by the OEM, for initial calibration.

Calibration

To calibrate the mechanical suspension, the following data has to be available.

Deflection of the Bogie from Unladen to Laden Condition

The deflection is very important to provide the RSS with the right information to calculate the actual axle load.

NOTE: Wrong information regarding the axle load can cause undesired interventions of the RSS system.

The values can be supplied by the suspension supplier. Figure 38. It is important to determine the correct suspension unladen load value, if calculating values from suspension supplier load versus deflection graph. Refer to the example below.

Example:

Characteristic of spring deflection provided by axle or spring manufacturer

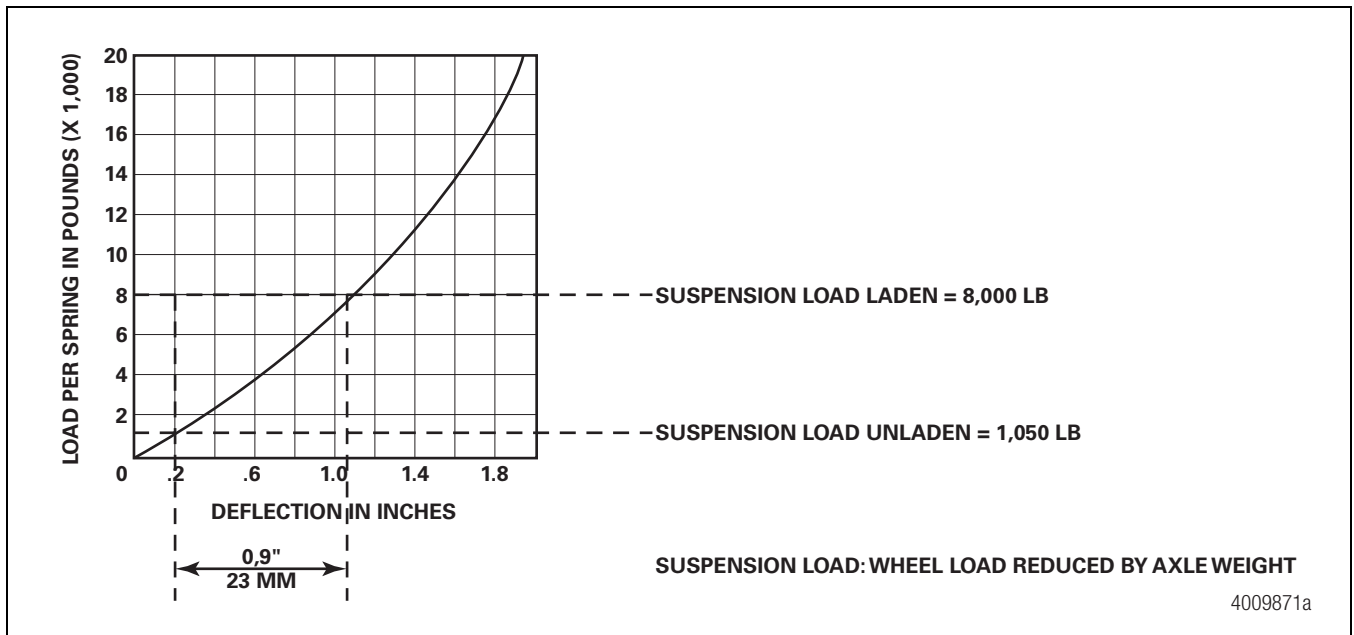

Figure 38

Table B: Example for Two Axle Semi Trailer

	Bogie Load	Bogie Load without Axle Weight	Suspension Load per Wheel
Max. Load:	34,000 lb	32,000 lb	8,000 lb
Unladen Load:	6,000 lb	4,200 lb	1,050 lb
Unladen Deflection:			0.25 inch
Laden Deflection:			1.15 inch
Difference (Input for Parameter Setting)			0.9 inch = 23 mm

Alternative Method to Determine Suspension Deflection

1. With the trailer **unloaded**, measure from the top of the axle tub (A) to a fixed point (B) on the underside of the trailer. Note the distance. Figure 39.

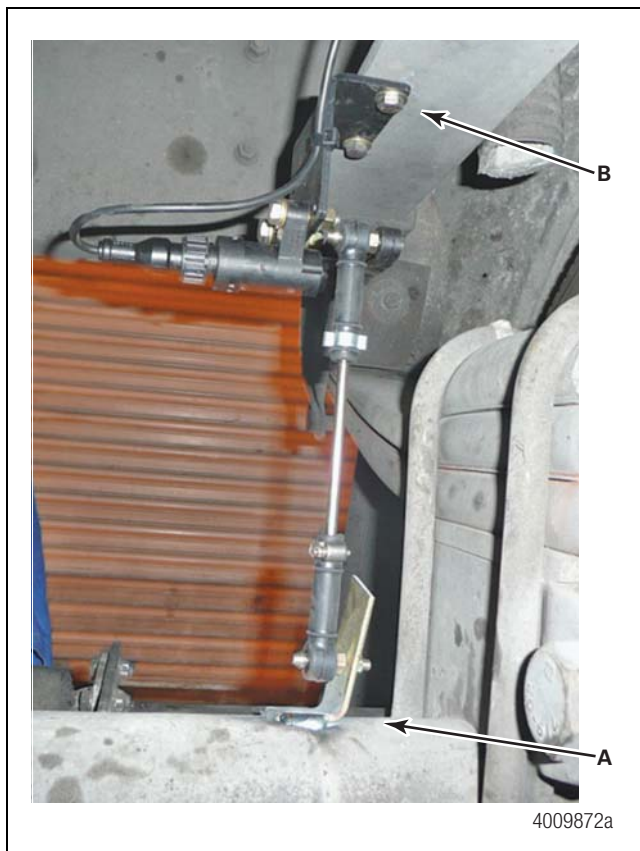

Figure 39

2. With the trailer loaded (maximum load), measure from the same points (A and B) that were used for the trailer **unloaded** measurement. It is important to ensure the maximum load is distributed uniformly (front to back, left to right) to avoid an inclined trailer condition. Note the distance.
3. Subtract the trailer **loaded** distance from the trailer **unloaded** distance. Note the difference. This is the spring deflection rate for this trailer.

NOTE: Provide the deflection rate in millimeters.

Negative Spring Deflection

Negative spring deflection means that the suspension is moving beyond the unladen position in a negative direction due to the clearance in the suspension.

This value is important to determine the correct length “l” of the distance sensor. Figure 40. It must be ensured that under every condition, the length of the lever is longer than the negative deflection to prevent the lever from turning over. If the lever is too long, the optimal resolution will be affected and lead to less precise axle load measurements. A lever length of 150 mm should be sufficient for the most types of axles. The negative deflection can be measured by lifting the axle without the distance sensor with a suitable jack until the other axle does not touch the ground. Contact WABCO for applications which may require a longer extension arm length greater than 150 mm.

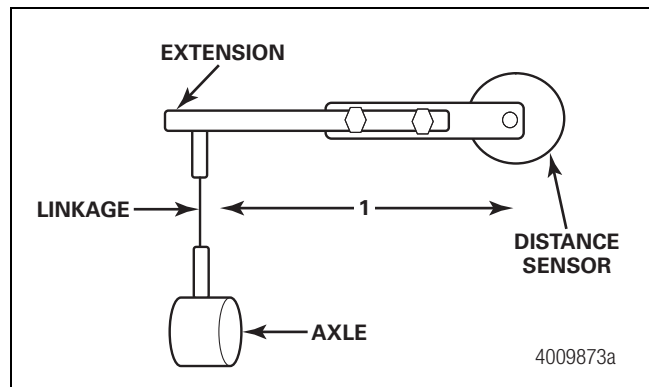

Figure 40

Conditions for Calibration

- The correct values are entered and stored in the ECU for unladen and laden deflections and loads.
- The trailer must be located on a level surface.
- The trailer has to be in an unladen condition.
- In the unladen condition, the lever of the distance sensor has to be in the horizontal position.

- Ensure that the distance sensor has been installed correctly and the lever can move without collision with the trailer frame. Refer to the installation guide.
- Chassis level
 - **Single-Axle Semi Trailer:**
No special requirements.
 - **Two-Axle Semi Trailer:**
The king pin must be in the lowest position which may occur during trailer operation with different tractors.
- During calibration, the trailer brakes have to be released (service brake and spring brake).

The final calibration is done using TOOLBOX™ Software. Please follow the software instructions.

Trailer Labels

Before releasing the trailer:

1. Affix the ABS indicator label to the trailer. The label should be on the side of the trailer near the ABS indicator lamp. Figure 41.

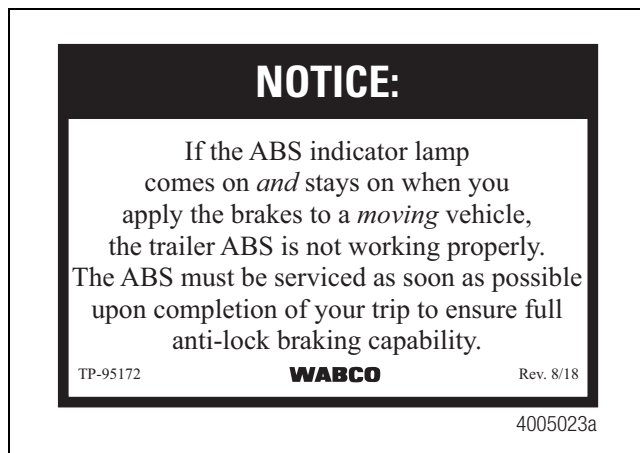

Figure 41

2. Affix the constant power label (part number 899 201 833 4) to the front of the trailer, near the seven-way connector. Figure 42.

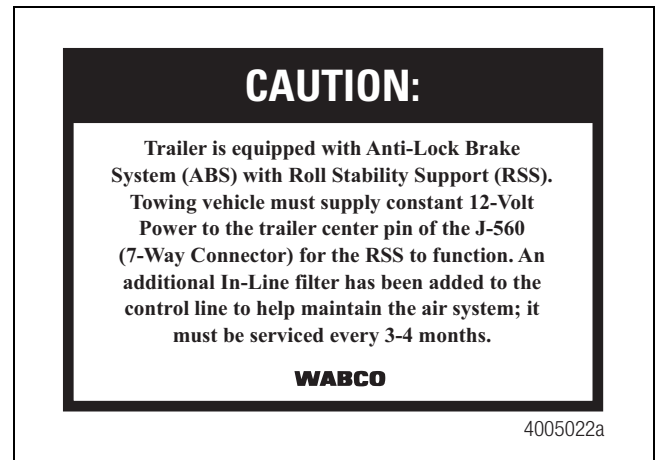

Figure 42

3. Affix the in-line filter label (part number 899 201 842 4) to the front of the trailer near the control (blue) gladhand. Figure 43.

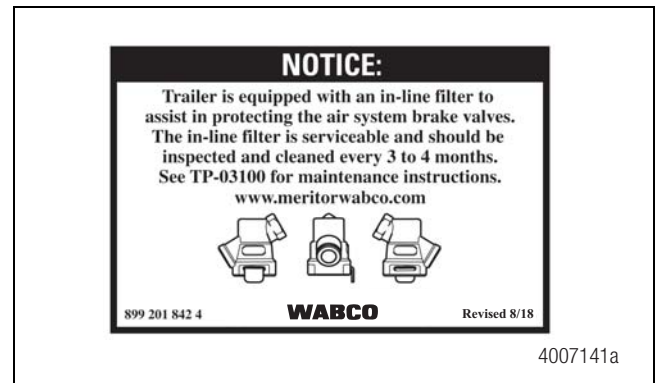

Figure 43

Parameter Entry

Vehicle Parameter Records

All RSSplus™ ECUs have default parameters already programmed into the unit. If you are installing a 4S/2M system with the ECU facing FORWARD on an air suspension, there is no need to change any parameters. Once the system is installed, you may proceed in this manual directly to Preparing to Release the Trailer.

If you are installing the RSSplus™ system in a non-default configuration, you will need to access the vehicle parameters. Contact your WABCO representative for assistance with non-default configurations.

From the TOOLBOX™ Software main screen, select the RSSplus™ icon. Figure 44.

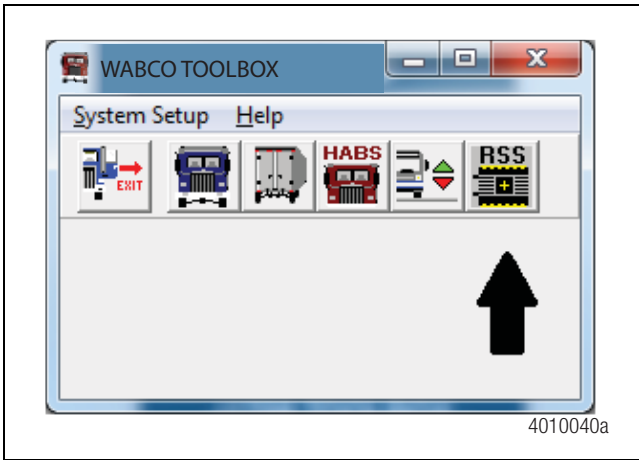

Figure 44

The RSSplus™ main screen appears. Figure 45.

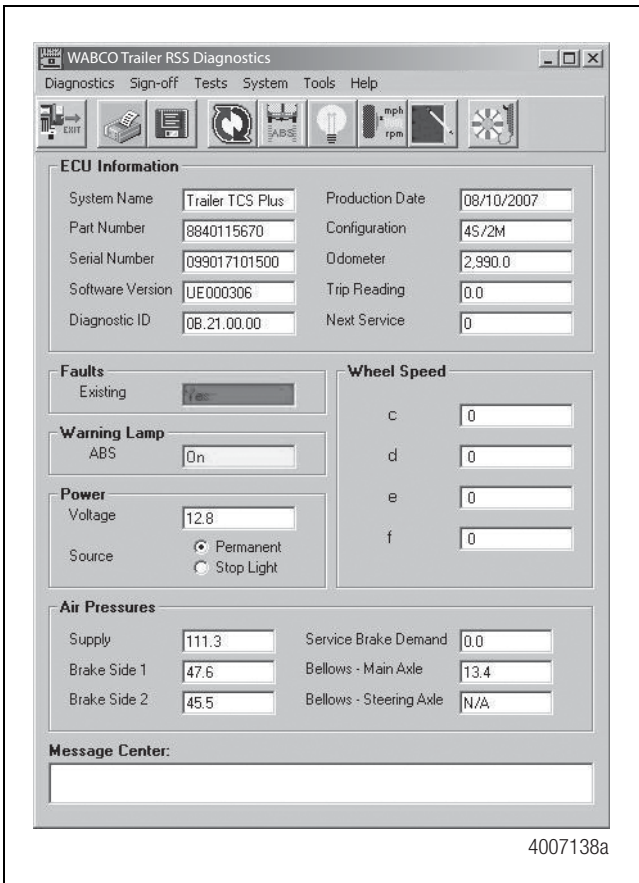

Figure 45

From the main screen, select **System** and then **Edit Parameters From ECU**. Figure 46.

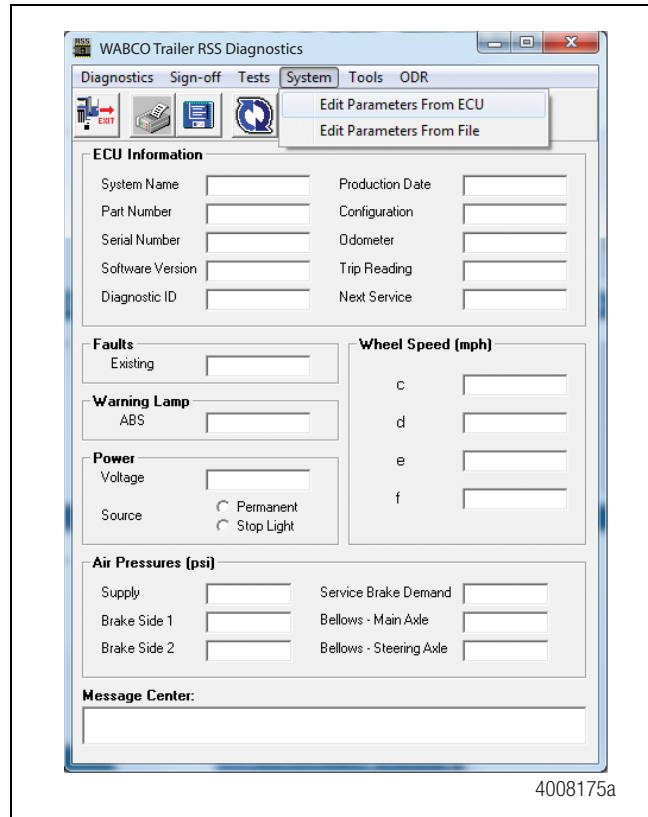

Figure 46

RSS System Parameters allows you to correctly configure the system to match the trailer's specific characteristics. The RSSplus™ ECU comes preprogrammed with default parameters and requires no further programming. You will need to add vehicle data. Press **Next** to continue. Figure 47.

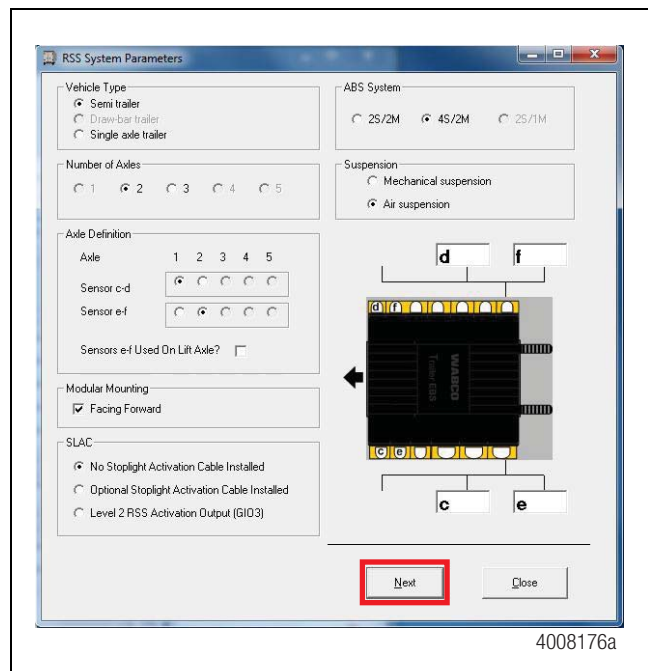

Figure 47

Air Suspension Parameters

Vehicle Type— Select the appropriate trailer type.

Number of Axles— Select the total number of axles on the trailer.

Axle Definition— Select the sensed axles by indicating the location of each sensor pair. Lift axles are not sensed and are controlled by generic I/O function. The on-screen illustration will change to reflect the sensor configuration.

Modulator Mounting— A modulator facing FORWARD will have the mount bolts pointing TOWARD the rear of the trailer. A forward facing ECU will have this box checked.

ABS System— Select the appropriate ABS type being installed.

Suspension— Select air suspension. **NOTE:** Mechanical suspensions are covered in the Mechanical Suspension Parameters section.

Optional Stoplight Activation Cable— Select this field ONLY if the stoplight activation cable is installed. This optional cable will activate the trailer brake lights when an RSS condition occurs.

Once all the parameters are correctly input, press the **NEXT** button to advance to the next parameter screen. Figure 48.

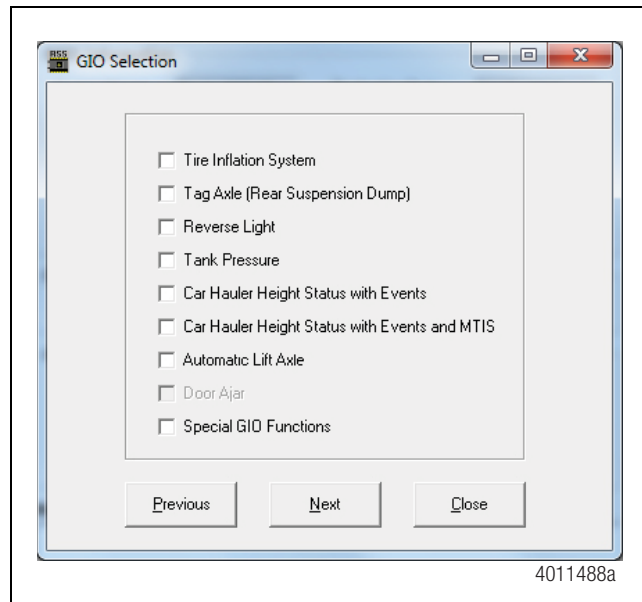

Figure 48

The GIO Selection Screen allows the user to pick which Generic Input/Output files are to be loaded into the ECU. Many of these optional functions are utilized in conjunction with the WABCO PLC Display.

Tire Inflation System— The WABCO Tire Inflation System Remote Warning.

Tag Axle (Rear Suspension Dump)— Releases air from a designated axle to facilitate tight turning.

Reverse Light— Activates a light that should illuminate when the trailer is being moved in reverse.

Tank Pressure— Warns if the trailer air reservoir experiences low pressure.

Car Hauler Height Status with Events— Warns if car decks are not in the locked-down position.

Car Hauler Height Status with Events and MTIS— Warns if car decks are not in the locked-down position, coupled with the MTIS function.

Lift Axle— Activates the automatic Lift Axle function.

Door Ajar— Warns driver if a secure door is not in the locked position.

Special GIO Functions— Customized functions specific to the trailer. Click in the appropriate check box to select the function that has been installed on the trailer. Press **NEXT** to advance to the next parameter screen. Figure 49.

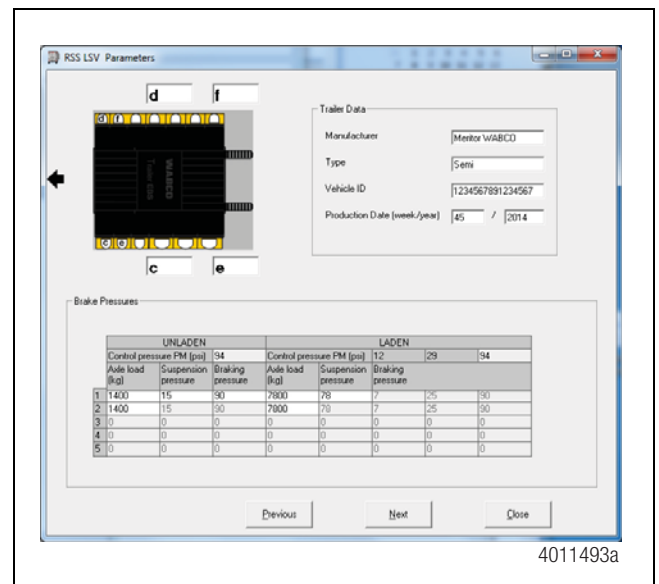

Figure 49

Trailer Data— This area contains important data about the trailer.

Manufacturer— Enter the manufacturer of the trailer.

Type— Enter the trailer type such as tanker, flatbed, van, etc.

Vehicle I.D.— Enter the last seven digits of the trailer VIN number or the fleet's trailer number. Do not leave this field blank as the software creates files using what is entered in this field as file names.

Production Date— Enter the trailer's production date by week number and year.

Brake Pressures— This area contains parameters affecting how the trailer brakes perform. These fields are unavailable with mechanical suspensions.

Additional Characteristic Point— This box is normally left blank. Checking this box allows brake pressure characteristics to be altered across four bands instead of the standard three.

Unladen Axle Load (kg)— Enter the amount of weight each axle will bear when the trailer is empty. The weight in kilograms can be converted from pounds with the formula 2.2 pounds equals 1 kilogram.

Unladen Suspension Pressure— The amount of air pressure found in the suspension air bags when the trailer is empty. The suspension pressure is measured in psi (pounds per square inch).

Unladen Braking Pressure— The default setting is 90 psi. If brake proportioning is desired, the setting may be less than 90 psi. Do not set this value below 38 psi.

Laden Axle Load— Enter the amount of weight each axle will bear when the trailer is fully loaded. The weight in kilograms can be converted from pounds with the formula 2.2 pounds equals 1 kilogram.

Laden Suspension Pressure— The amount of air pressure found in the suspension air bags when the trailer is fully loaded. The suspension pressure is measured in psi (pounds per square inch).

Laden Braking Pressure— Values in these output fields affect the trailer's brake performance in the laden condition. There are three columns (left to right) that affect light, medium, and heavy braking. Please contact WABCO North America Customer Care at 855-228-3203 for assistance if changing these values from the default values.

Once all the values have been correctly determined and entered, press the **NEXT** button to advance to the last Parameter screen. Figure 50.

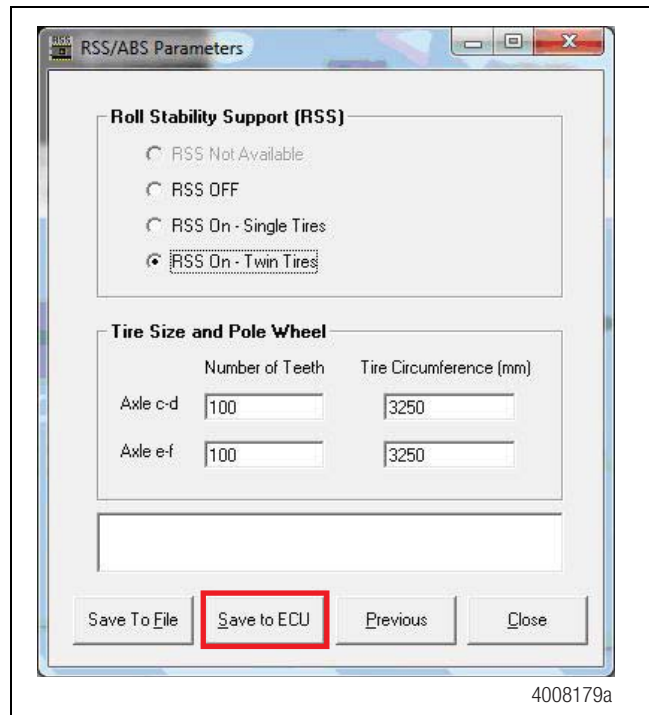

Figure 50

Roll Stability Support— If the trailer will have a single wheel on each side of the axle (“Super Singles”), select **RSS ON — Single Tires**. If the trailer will have dual wheels on each side of the axle, select **RSS On — Twin Tires**. Only select **RSS Off** if no roll stability is desired.

Tire Size and Pole Wheel— The Number of Teeth field is for the quantity of teeth on the tone ring. Nearly all tone rings have 100 teeth. The **Tire Circumference** is the dynamic tire radius of the tire in millimeters. The default setting of 3100 will be applicable to most tires, although an exact figure can be obtained from the tire's manufacturer.

Once the parameters have been entered, press the **Save to ECU** button. The parameters are then saved to the ECU. You are now ready to proceed to the sign-off procedure.

After storing parameters in the ECU, the End-of-Line Start-Up Procedure must be performed. Proceed to the System Sign-Off procedure.

Mechanical Suspension Parameters

There are additional parameters for a mechanical suspension trailer that must be configured before releasing the trailer into service.

NOTE: The distance the springs on a mechanical suspension compress between unladen and laden states is known as “deflection”. This value, in millimeters, **MUST** be obtained from the suspension manufacturer prior to programming the ECU. WABCO does not have and cannot provide this essential information. If the value cannot be obtained from the suspension manufacturer, the following procedure can be performed to obtain the value.

Determine Spring Deflection Rate

- With the trailer **unloaded**, measure from the top of the axle tube (A) to a fixed point (B) on the underside of the trailer. Note the distance. Figure 51.
- With the trailer **loaded** (maximum load), measure from the same points (A and B) that were used for the trailer unloaded measurement. Note the distance. Figure 51.
- Subtract the trailer **loaded** distance from the trailer **unloaded** distance. Note the difference. This is the spring deflection rate for this trailer.

NOTE: Provide the deflection rate in millimeters.

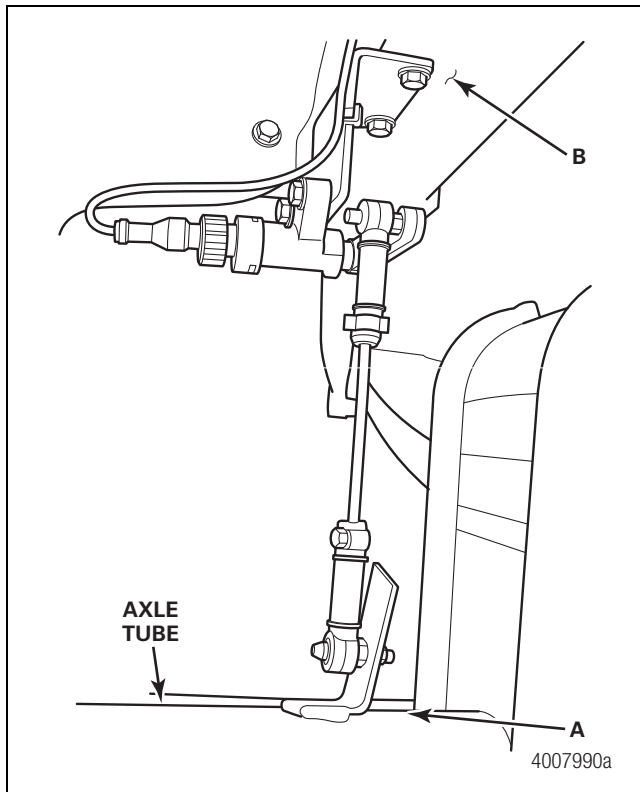

Figure 51

From the main screen, select **System** and then **Edit Parameters From ECU**. Figure 52.

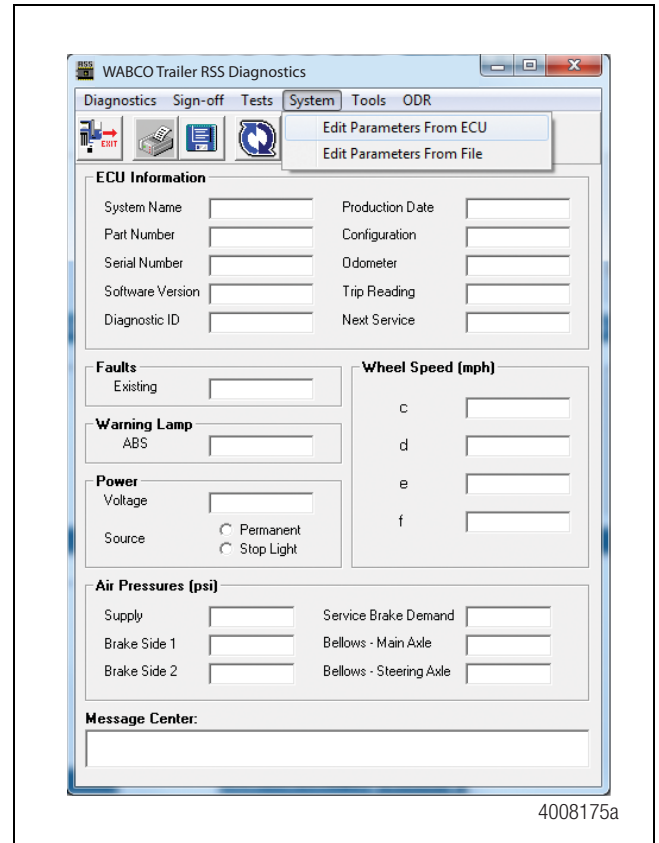

Figure 52

Input the correct values for each data area. Figure 53.

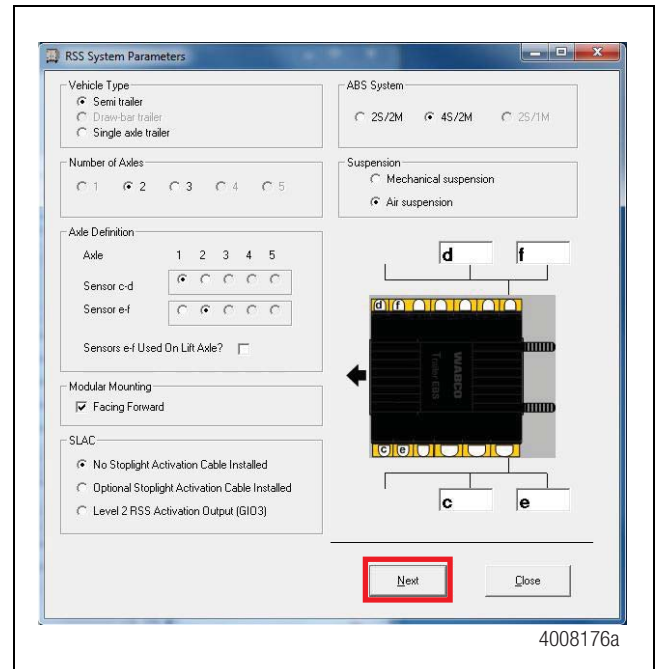

Figure 53

Vehicle Type— Select the appropriate trailer type.

Number of Axles— Select the total number of axles on the trailer.

Axle Definition— Select the sensed axles by indicating the location of each sensor pair. Lift axles are not sensed and are controlled by generic I/O function. The on-screen illustration will change to reflect the sensor configuration.

Modulator Mounting— A modulator facing FORWARD will have the mount bolts pointing TOWARD the rear of the trailer. A forward facing ECU will have this box checked.

ABS System— Select the appropriate ABS type being installed.

Suspension— Select Mechanical Suspension.

Optional Stoplight Activation Cable— Select this field ONLY if the stoplight activation cable is installed. This optional cable will activate the trailer brake lights when an RSS condition occurs.

When all fields are correctly configured, press **NEXT** to advance to the second parameter screen. Figure 54.

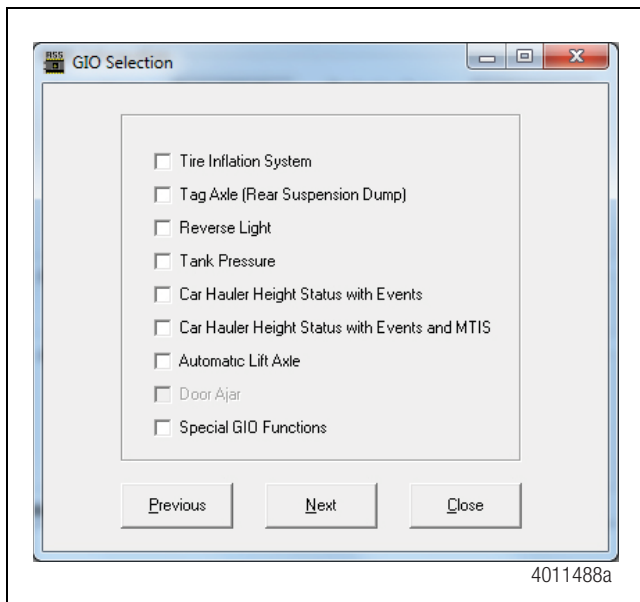

Figure 54

The GIO Selection Screen allows the user to pick which Generic Input/Output files are to be loaded into the ECU. Many of these optional functions are utilized in conjunction with the WABCO PLC Display.

Tire Inflation System— The WABCO Tire Inflation System Remote Warning.

Tag Axle (Rear Suspension Dump)— Releases air from a designated axle to facilitate tight turning.

Reverse Light— Activates a light that should illuminate when the trailer is being moved in reverse.

Tank Pressure— Warns if the trailer air reservoir experiences low pressure.

Car Hauler Height Status with Events— Warns if car decks are not in the locked-down position.

Car Hauler Height Status with Events and MTIS— Warns if car decks are not in the locked-down position, coupled with the MTIS function.

Lift Axle— Activates the automatic Lift Axle function.

Door Ajar— Warns driver if a secure door is not in the locked position.

Special GIO Functions— Customized functions specific to the trailer. Click in the appropriate check box to select the function that has been installed on the trailer. Press **NEXT** to advance to the next parameter screen. Figure 55.

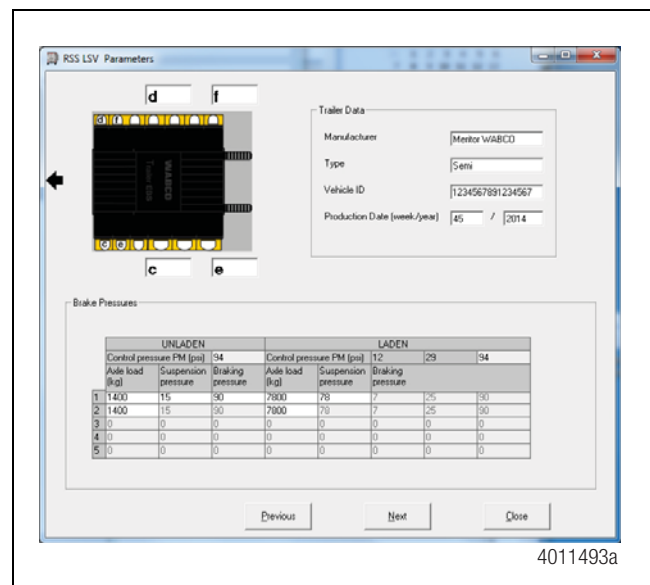

Figure 55

Trailer Data— This area contains important data about the trailer.

Manufacturer— Enter the manufacturer of the trailer.

Type— Enter the trailer type such as tanker, flatbed, van, etc.

Vehicle I.D.— Enter the last seven digits of the trailer VIN number or the fleet's trailer number. Do not leave this field blank as the software creates files using what is entered in this field as file names.

Production Date— Enter the trailer's production date by week number and year.

Unladen Axle Load (kg)— Enter the amount of weight each axle will bear when the trailer is empty. The weight in kilograms can be converted from pounds with the formula 2.2 pounds equals 1 kilogram.

Unladen Suspension Path— This value is typically zero for an empty (unladen) trailer.

Unladen Braking Pressure— The default setting is 90 psi. If brake proportioning is desired, the setting may be less than 90 psi. Do not set this value below 38 psi.

Laden Axle Load— Enter the amount of weight each axle will bear when the trailer is fully loaded. The weight in kilograms can be converted from pounds with the formula 2.2 pounds equals 1 kilogram.

Laden Suspension Path— This value is the amount of spring compression (in millimeters) when the trailer is fully laden. This value is obtained by the trailer builder from the mechanical suspension manufacturer.

Laden Braking Pressure— Values in these output fields affect the trailer's brake performance in the laden condition. There are three columns (left to right) that affect light, medium, and heavy braking. Please contact WABCO North America Customer Care at 855-228-3203 for assistance if changing these values from the default values.

Distance Sensor Lever Length— The software defaults to 100 mm. This is the setting when the distance sensor lever is mounted to the farthest integrated nut on the distance sensor. If the lever is mounted to the center integrated nut on the distance sensor arm, the value is 50 mm.

Once all the values have been correctly determined and entered, press the **NEXT** button to advance to the last Parameter screen. Figure 56.

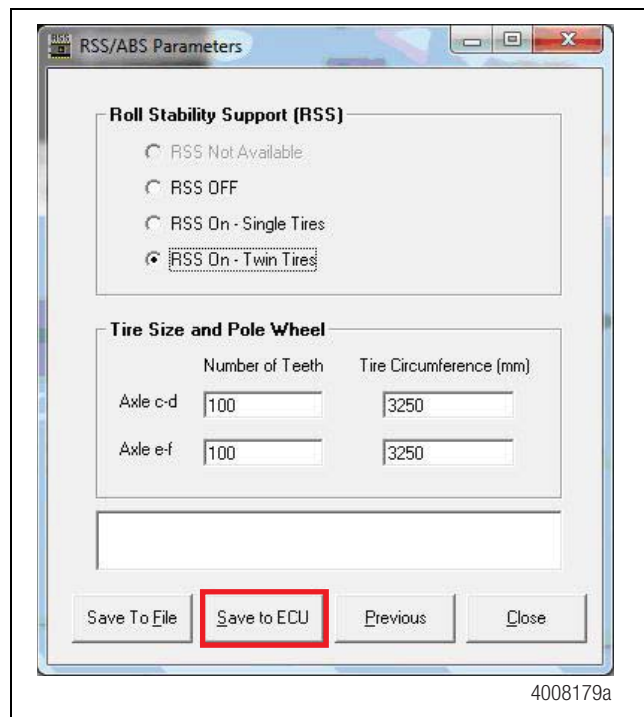

Figure 56

Roll Stability Support— If the trailer will have a single wheel on each side of the axle (“Super Singles”), select **RSS ON — Single Tires**. If the trailer will have dual wheels on each side of the axle, select **RSS On — Twin Tires**. Only select **RSS Off** if no roll stability is desired.

Tire Size and Pole Wheel— The Number of Teeth field is for the quantity of teeth on the tone ring. Nearly all tone rings have 100 teeth. The **Tire Circumference** is the dynamic tire radius of the tire in millimeters. The default setting of 3100 will be applicable to most tires, although an exact figure can be obtained from the tire's manufacturer.

Once the parameters have been entered, press the **Save to ECU** button. The parameters are then saved to the ECU. You are now ready to proceed to the sign-off procedure.

System Sign-Off (End of Line Testing)

End of line testing is required on all trailer RSS installations. Use WABCO diagnostic software to perform this test. This software must be available at all trailer manufacturers where RSS is being installed. If you do not have this software program, please contact WABCO North America Customer Care at 855-228-3203.

System Sign-Off Procedure

1. Connect the vehicle to a computer with WABCO diagnostic software installed.
 - Attach the serial or USB cable from your computer to the WABCO interface box.
 - Attach one end of the vehicle diagnostic connector to the adapter box. Attach the other end to the diagnostic connector on the trailer. Figure 57.

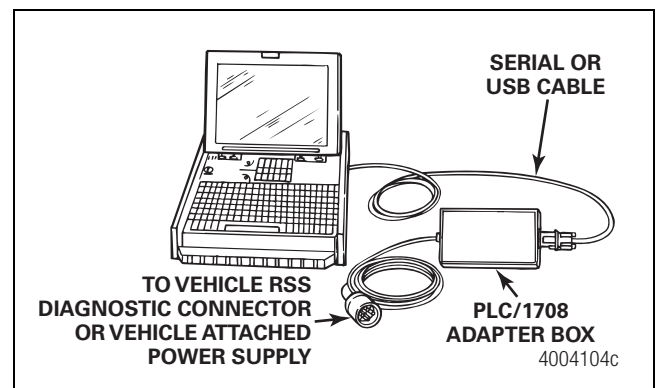

Figure 57

2. Double click on the TOOLBOX™ Software icon on your computer to launch the program. Figure 58.
 - Read the warning notice that appears and click **Yes** to continue. If you select **No**, you will exit the program.

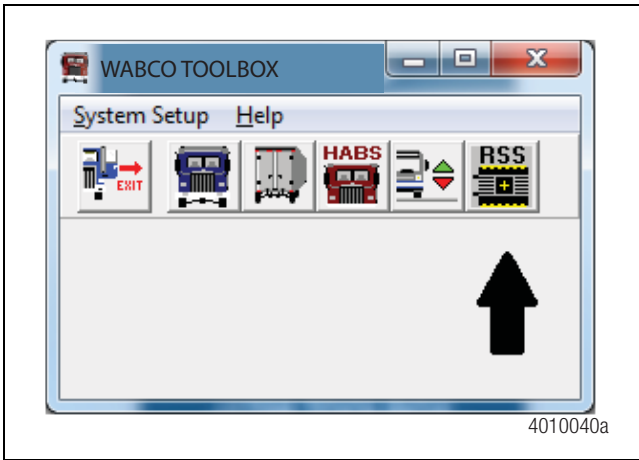

Figure 58

- Click the RSS icon.

Preparing to Release the Trailer

NOTE: No existing (active) faults, other than Parameter Setting (Special Faults) can be present during System Sign-Off. All faults must be cleared before proceeding. Figure 59.

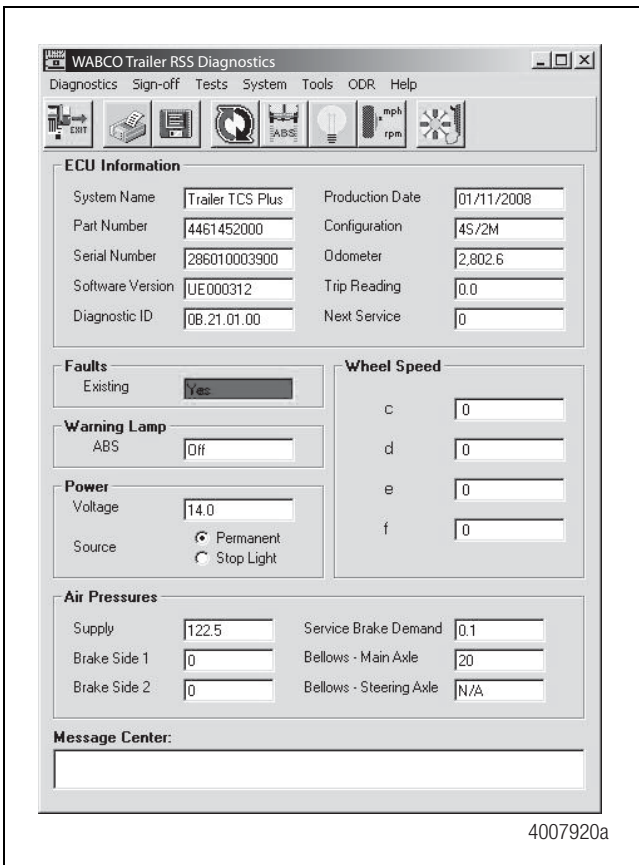

Figure 59

Putting the Trailer into Service

The RSS^{plus}™ comes with factory set default parameters of a tandem axle 4S/2M system on an air suspension. If you are installing the RSS^{plus}™ system in a non-default configuration, or wish to take advantage of the RSS^{plus}™'s additional capabilities, you must edit and save the parameters before performing the End of Line test.

Sign-Off Procedure

Once installed, the WABCO RSS^{plus}™ system must go through a sign-off procedure. This ensures that the system has been correctly installed and the pneumatic functions of the trailer are supporting the Roll Stability ABS.

In order to run the sign-off procedure, the trailer must be connected to 12 volt DC power (10 amp minimum), be connected to supply air (120 psi), have the capability to have control line air applied, and have the sensed axles raised off the ground.

From the Main Screen, select **Sign-Off** from the pull-down menu bar. Then select **Begin Sign-Off Procedure** to begin the automated test procedure. Figure 60.

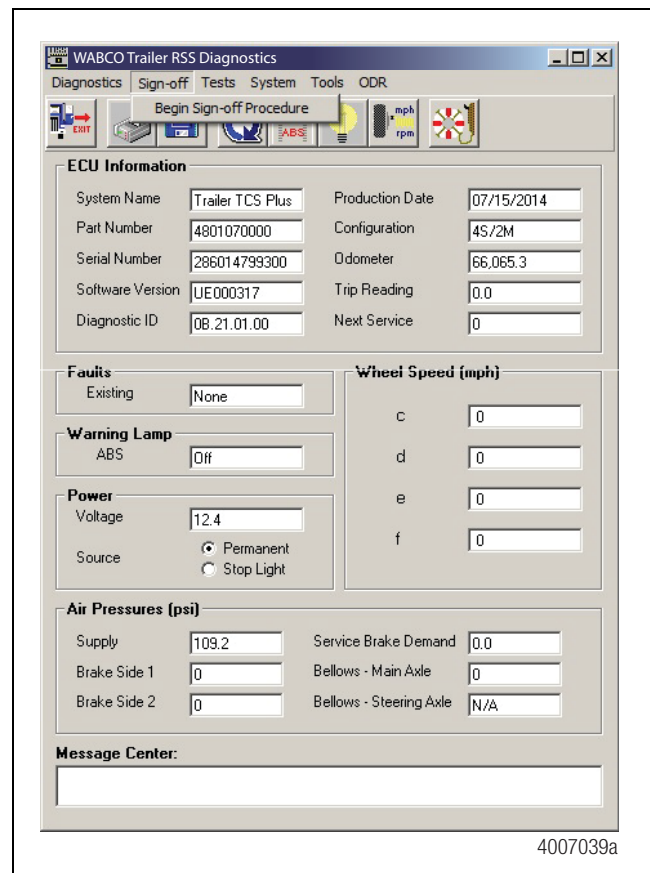

Figure 60

The Sensor Test

This portion of the sign-off will check the placement of the ABS wheel sensors. Ensure there is no pressure on the control (blue) line and that the trailer has all ABS sensed axles up off the ground. The following message will appear. Press **OK** after all safety precautions have been taken and release the **blue** air line to begin the test. Figure 61.



Figure 61

Lift all sensed wheels off the ground by jacking the appropriate axle. Rotate each wheel individually (in the order shown on the screen) and check the on-screen diagram to ensure correct sensor placement. **Errors will occur if the wheels are spun faster than 10 mph (16 kph).** Once the placement of all sensors has been correctly verified, press the **Close** button. Figure 62.

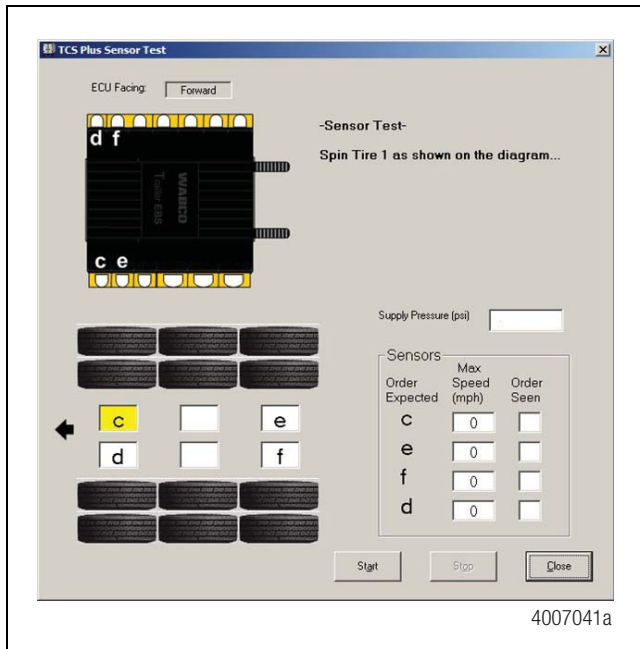

Figure 62

The Warning Lamp Test

This portion of the sign-off will ensure correct operation of the ABS warning lamp. The warning light will flash on and off. Wait for the test to end before pressing the **Close** button. Figure 63.



Figure 63

Distance Sensor Calibration

If the trailer has a spring suspension, the Mechanical Suspension Calibration screen will appear. Ensure that the trailer is now lowered so that all axles are fully on the ground. Figure 64 and Figure 65.

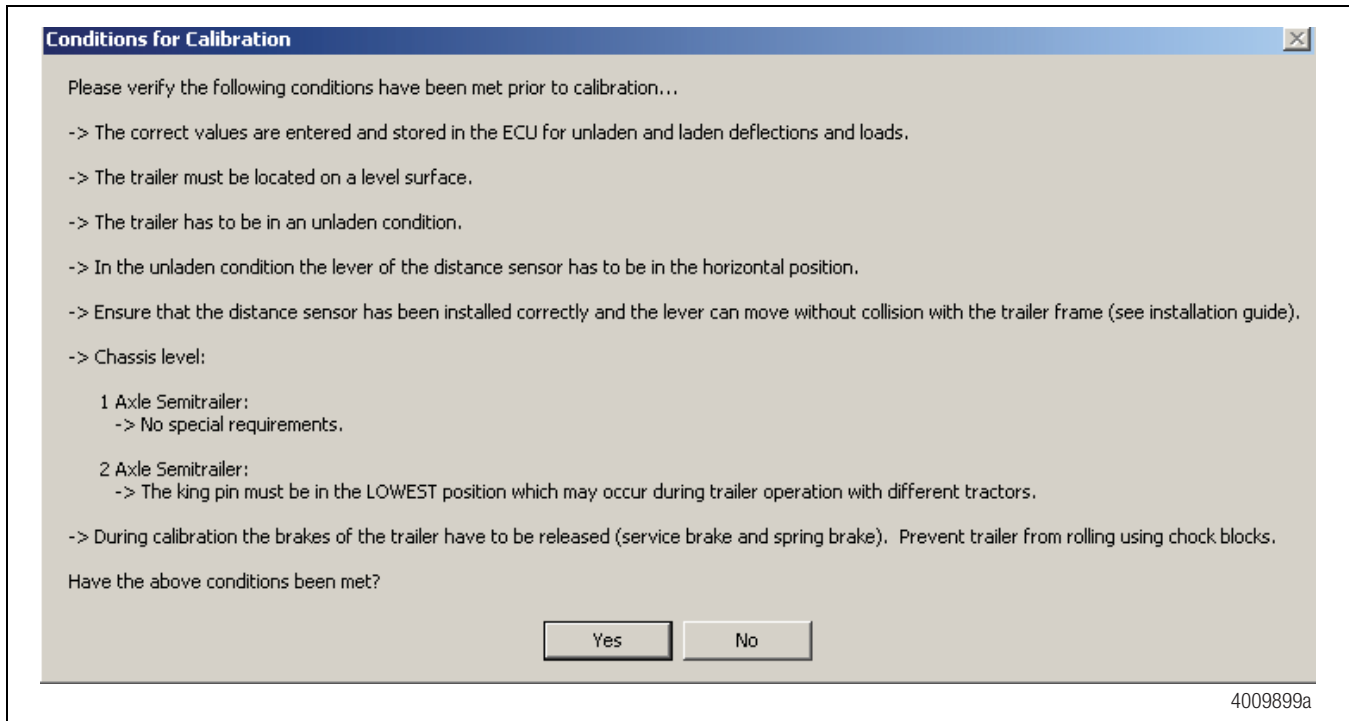

Figure 64

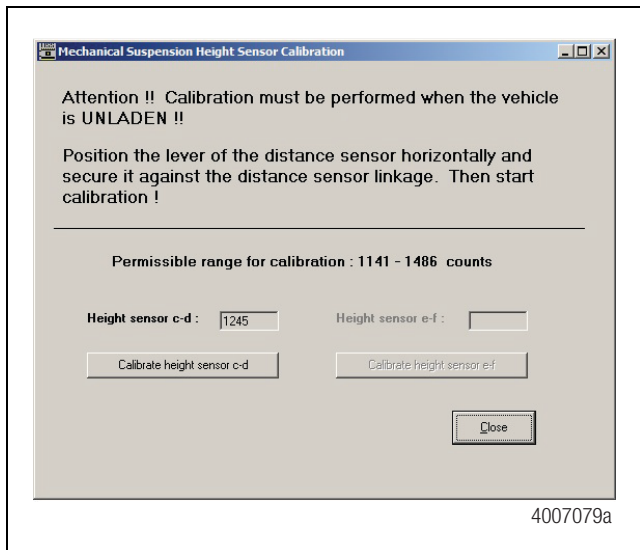

Figure 65

Ensure the Distance Sensor arm is parallel to the ground. The trailer must be in the unladen (empty) state. If the displayed value is beyond the listed range, you will need to adjust the Distance Sensor. Once the value in the "Height Sensor" field no longer changes and is within the specified range, press the button labeled **Calibrate Height Sensor**.

A message appears if the calibration is successful. Press OK. Figure 66.

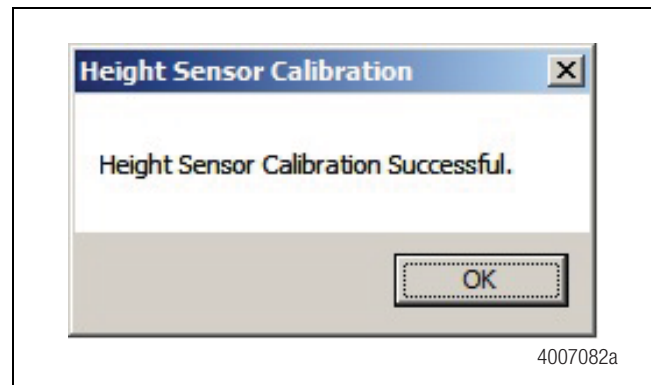

Figure 66

Once the calibration is successful, remove the small rod from the Distance Sensor.

Successfully signing off the trailer will produce the confirmation screen and allow the tester the opportunity to save the results. Click on the **Yes** button and save the file in the appropriate data directory. Figure 67.

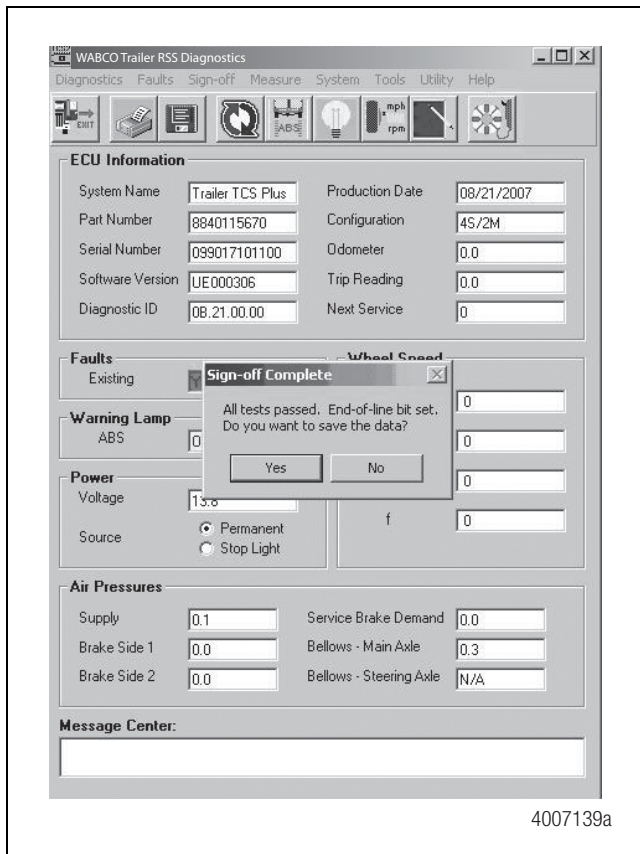

Figure 67

A message appears confirming the file has been saved and shows the location of the data. Figure 68.



Figure 68

RSS Diagnostics

Blink Code Diagnostics

The WABCO RSSplus™ ABS ECU detects any electrical fault in the trailer ABS. Each of the faults has a code. When a fault occurs, the ECU stores the code for that fault in the memory.

There are two kinds of faults: active and stored. Active faults are those currently existing in the system, such as a broken wire. Stored faults are faults that have occurred but do not presently exist. Active faults can be cleared only after repairs are completed. Both Active and Stored faults can be diagnosed with TOOLBOX™ Software. Active faults can be diagnosed with blink codes.

The ECU signals a malfunction by lighting both the internal and external indicator lamp when a fault exists. The external ABS indicator lamp is usually mounted on the left rear of the trailer, near the rear wheels.

Blink codes may be initiated by Ignition Power Activation (recommended method).

Although the ECU can store multiple faults in its memory, it only displays one blink code at a time. This is why it is important to recheck the blink codes after repairing a fault. If there are additional codes in the memory, they only blink after you have repaired the first fault.

Clearing stored faults is performed with the TOOLBOX™ Software.

Ignition Power Activation

Ignition Power Activation is the process of using the vehicle's ignition switch (or interrupting the power on the blue wire by some other means) to display blink codes on the trailer ABS indicator lamp located on the side of the trailer. This method is for constant power vehicles only.

To obtain blink codes using ignition power activation, perform the following procedure:

1. Turn the ignition switch on for no longer than five seconds. The ABS indicator lamp will be on.
2. Turn the ignition switch off for one second. The ABS indicator lamp will go out.
3. Turn the ignition switch on. The ABS indicator lamp will then come on, then go out.
4. The blink code will be displayed three times by the ABS indicator lamp on the trailer.

The following blink codes are defined:

Blink Code Counts	Component Name
0	No failure
3	Sensor failure c
4	Sensor failure d
5	Sensor failure e
6	Sensor failure f
7	External modulator failure
9	Internal modulator failure H2

Blink Code Counts	Component Name
10	Internal modulator failure H1
11	No speed failure
12	Control pressure failure
13	Supply pressure failure
14	Power supply failure
15	ECU internal failure*
16	SAE J 1708 failure
17	PLC failure
18	Generic IO failure
19	Load sensing failure
20	Roll stability system failure

*This error code will also appear on newly installed ECUs that have not been put into service with TOOLBOX™ Software End-of-Line test.

Computer Diagnostics

TOOLBOX™ Software

TOOLBOX™ Software is a PC-based diagnostics program that can display wheel speed data, test individual components, verify installation wiring and is required to perform a sign-off for the RSSplus™ installation.

WABCO TOOLBOX™ Software, Version 12.2 (or higher) supports RSSplus™. Figure 69. TOOLBOX™ Software is available for purchase via download 24 hours a day, seven days a week on wabco-na.com.

Computer requirements for TOOLBOX™ Software Version 12.2 are as follows.

- Pentium®-based PC or higher
- CD-ROM drive
- Windows® XP or higher operating system
- 512 MB RAM for Windows® Vista™/Windows® 7
- 60 MB hard drive disc space for full installation
- RP1210A compliant communications adapter for SAE J1708/J1587 or PLC
- USB port diagnostic adapter



Figure 69

Interface Adapter

A diagnostic interface is also required to connect the computer to the RSSplus™ ECU/valve.

The J-Pro trailer PLC adapter is highly recommended along with an appropriate trailer connection cable. Available from J-Pro at jprofleetproducts.com. Figure 70.

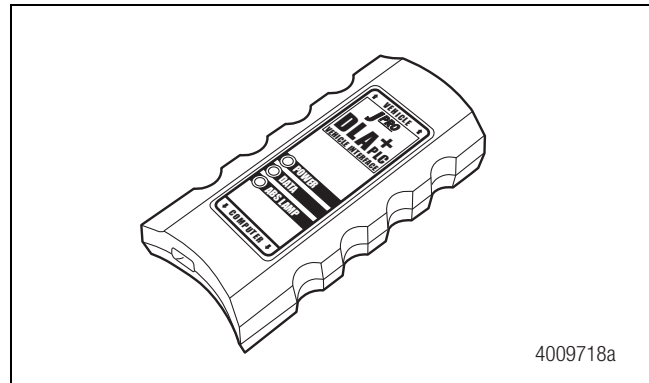

Figure 70

NOTE: USB/serial adapters do not work. The port must be either serial or USB.

Contact WABCO Trailer Engineering before purchasing these components to be certain that they will be compatible with your personal computer, version of Windows® and latest version of WABCO TOOLBOX™ Software.

Vista™/Windows® 7 Installations

If you have Microsoft Vista™/Windows® 7 installed on your computer, the Vista™UAC (User Access Control) must be disabled before installing the TOOLBOX™ Software. Have your computer support personnel or your IT (Information Technology) department perform this change. Once disabled, TOOLBOX™ Software can be installed without issue.

WABCO does not provide computer support.

If TOOLBOX™ Software has already been installed on your personal computer with Vista™/Windows® 7, your computer support personnel (IT department) must disable the UAC manually. Refer to Vista™ support documentation for the procedure.

NOTE: TOOLBOX™ Software has not been validated with Windows® 8.

Initiating RSSplus™ Diagnostics

1. From the main screen of TOOLBOX™ Software, click on the RSSplus™ icon. Figure 71.

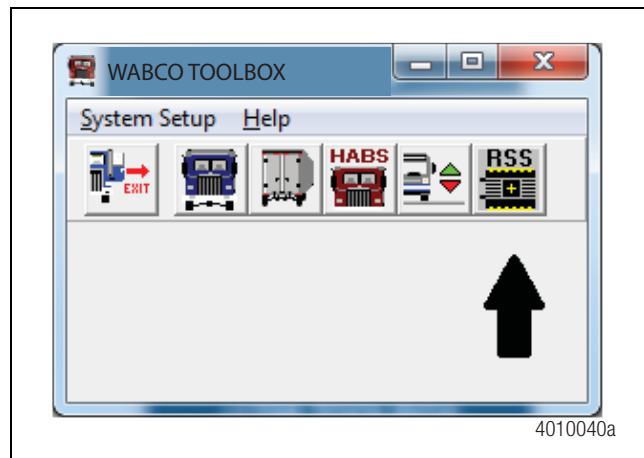

Figure 71

2. From the main screen of the WABCO trailer EBS diagnostics software, select **Diagnostics** from the top menu bar. Figure 72.

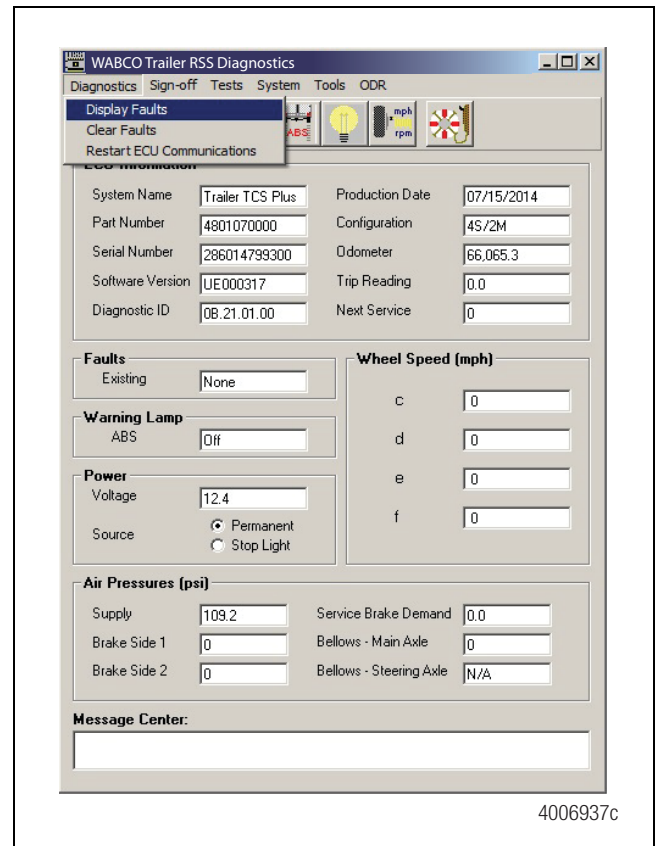

Figure 72

3. Select **Display Faults** from the pull-down menu. All active and stored faults are displayed. Figure 73.

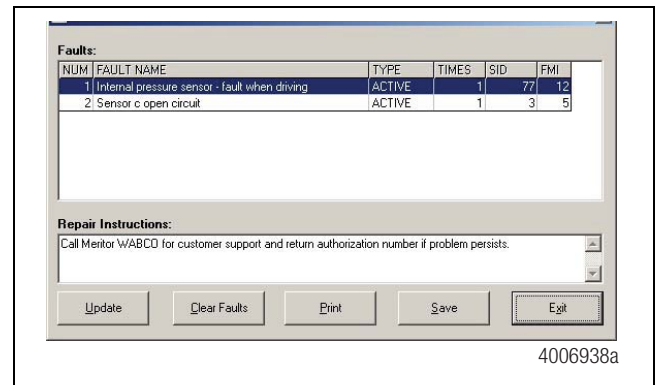

Figure 73

4. Repair active faults and take corrective action on stored faults. Once repaired, faults may be cleared by using the **Clear Faults** button.

Testing Components with TOOLBOX™ Software

The warning light, wheel sensors and the ECU valve can be tested as individual components. From the RSS*plus*™ main screen, activate the pull-down menu labeled TESTS. Select the component to be tested from the menu. Figure 74.

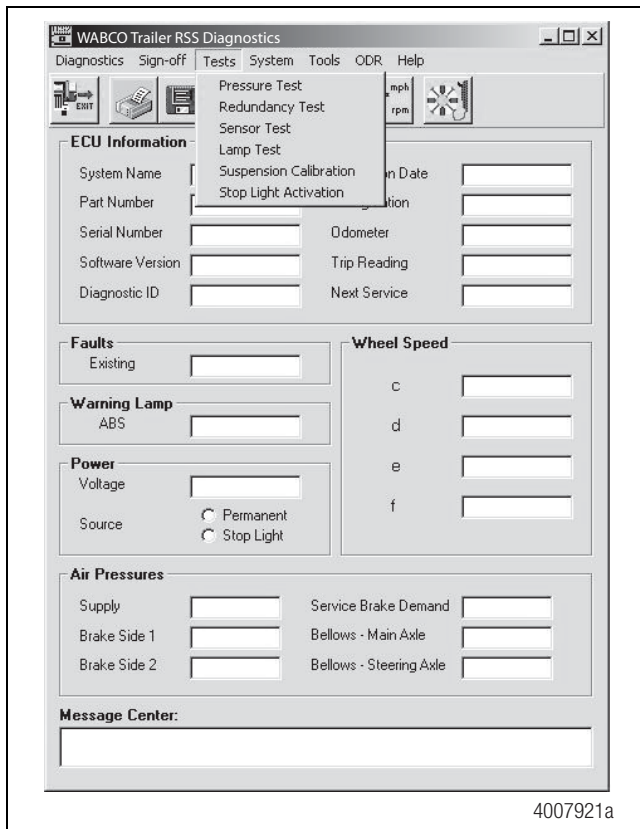

Figure 74

The Pressure Test

Initiating the menu selection labeled PRESSURE TEST will check the ECU's internal modulator valves for correct operation. Press the **START** button to begin the test. Once the test successfully concludes, press the **OK** button. Figure 75.

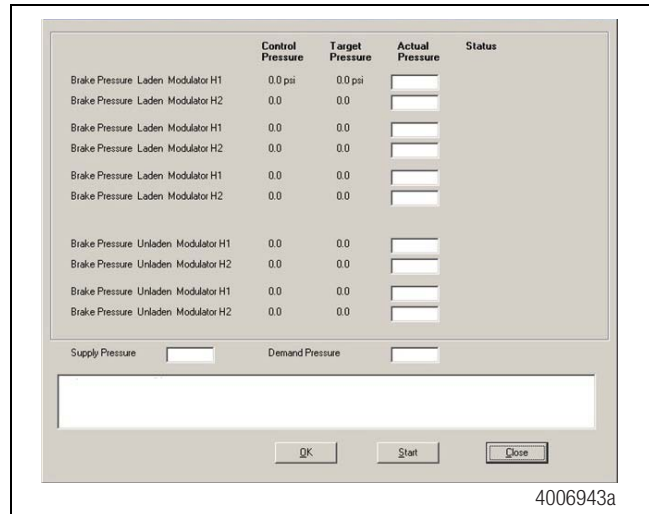

Figure 75

The Redundancy Test

Initiating the menu selection labeled REDUNDANCY TEST will check the pneumatic functionality of the trailer's air system to the RSS equipment. The Redundancy Test ensures the air capacity and control to the ECU is correct and measures the pressure at the internal modulator valves. Wait for the conclusion of the test and then press **OK**. Figure 76.

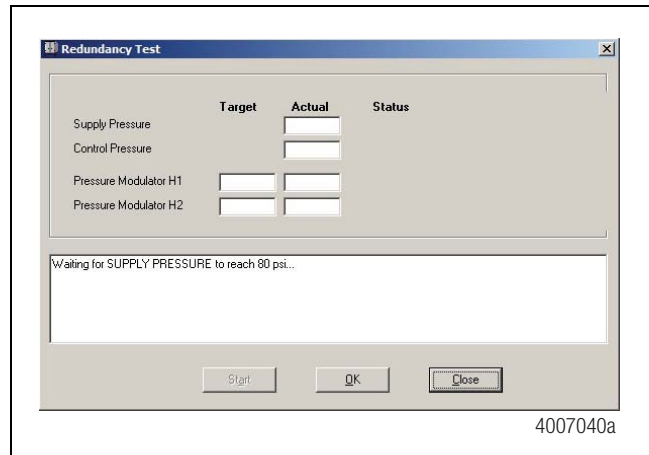

Figure 76

The Sensor Test

Initiating the menu selection labeled SENSOR TEST will check the placement of the ABS wheel sensors. The following warning will appear. Press **OK** when all safety precautions have been taken. Figure 77.



Figure 77

Lift the ABS sensed axles off the ground. Ensure there is no air pressure on the Control Line (blue) of the pneumatic brake system. Press **START** to begin the test. Rotate each wheel individually (in the order shown on the screen) and check the on-screen diagram to ensure correct sensor placement. Once the placement of all sensors has been correctly verified, press the **Close** button. Figure 78.

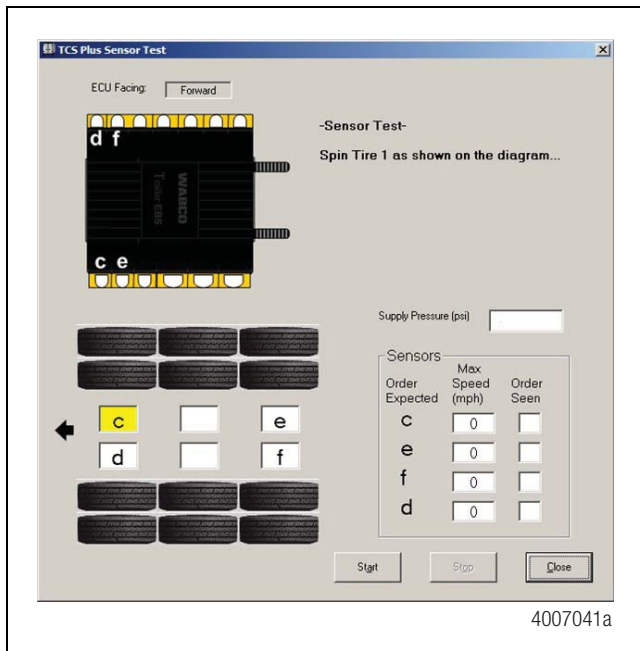

Figure 78

The Warning Lamp Test

Initiating the menu selection labeled LAMP TEST will check the activation of the trailer ABS warning light. Press the **TEST** button to begin the warning light test. The warning light will flash on and off. Press **Yes** to confirm the warning light is functioning correctly. Figure 79.



Figure 79

Distance Sensor Calibration

If the trailer has a spring suspension, the Mechanical Suspension screen will appear. Ensure that the trailer is now lowered so that all axles are fully on the ground. Figure 80 and Figure 81.

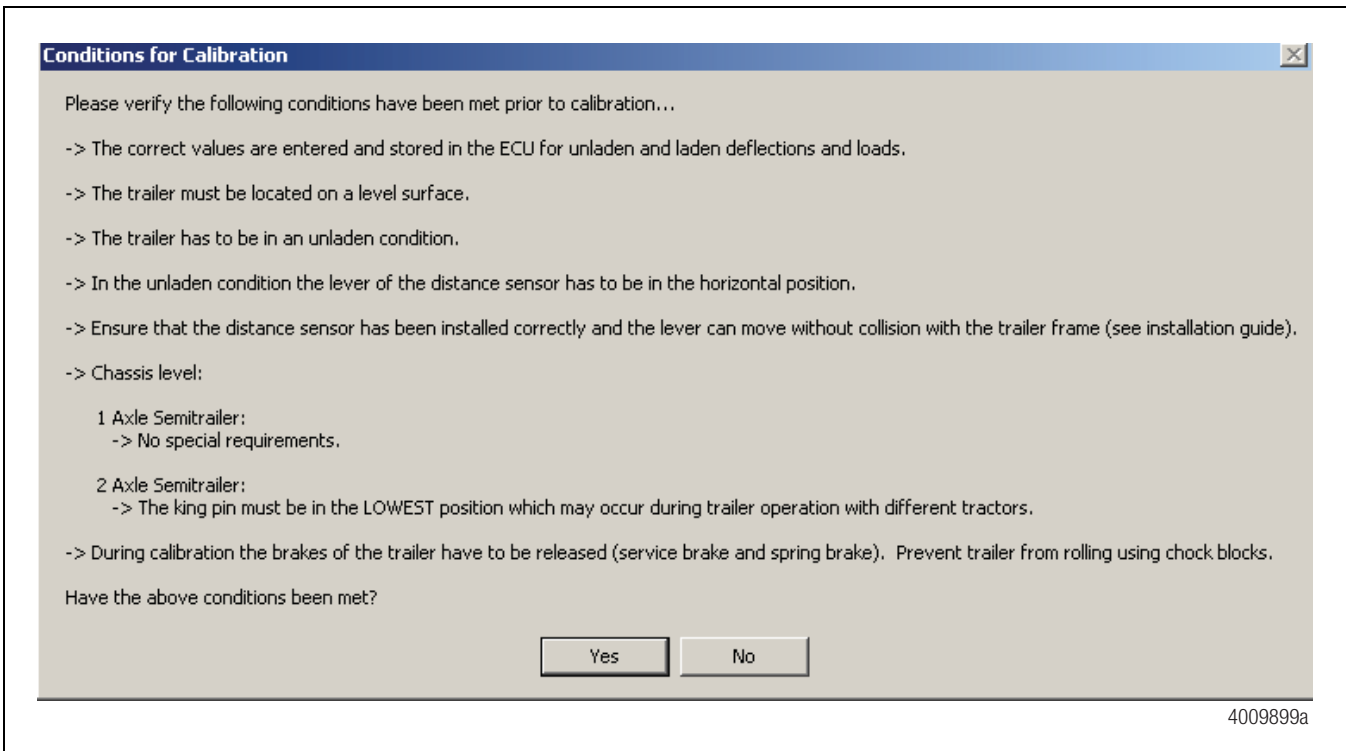

Figure 80

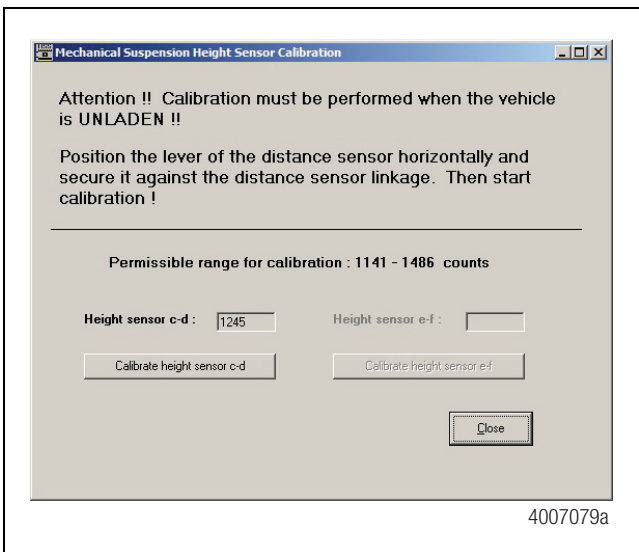

Figure 81

Ensure the Distance Sensor arm is parallel to the ground. The trailer must be in the unladen (empty) state. If the displayed value is beyond the listed range, you will need to adjust the Distance Sensor. Once the value in the "Height Sensor" field no longer changes and is within the specified range, press the button labeled **Calibrate Height Sensor**.

A message appears if the calibration is successful. Press OK. Figure 82.

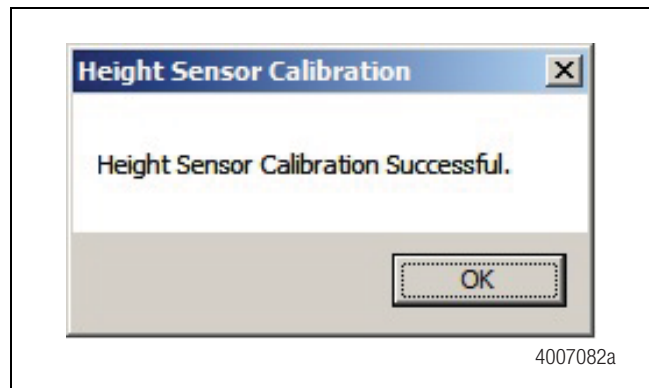

Figure 82

Stoplight Activation Cable

The activation of RSS event stoplights may be checked using this test. This test is conducted only if the optional stoplight activation cable is installed. Pressing the **Trailer 1 On** button turns the stoplights on. Press the **Trailer 1 Off** button to turn the stoplights off. Press the **Close** button to exit. Figure 83.



Figure 83

RSSplus™ Parts List

Part Number	Nomenclature	Detail
100 001 012 4	RSS Label	Adhesive
100 400 004 0	Axle Clamp	5.8" Diameter
431 700 001 0	Pressure Switch Over Ride	70 psi
432 500 005 0	In-Line Filter	
441 044 106 0	Transducer	15 bar (1/4" NPTF)
441 050 100 0	Distance Sensor	
441 050 712 2	Distance Sensor Linkage	
441 050 718 2	Extension Lever	Old Style
441 901 715 4	Extension Lever	Current Style
449 351 010 0	Power Cable	1 Meter
449 351 047 0	Power Cable	4.7 Meters
449 443 030 0	ATC Generic I/O Cable	3 Meters
449 446 020 0	Generic I/O Cable	2 Meters
449 535 020 0	Generic I/O Cable	2 Meters
449 535 040 0	Generic I/O Cable	4 Meters
449 535 060 0	Generic I/O Cable	6 Meters
449 639 030 0	Diagnostic Cable	3 Meters
449 639 050 0	Diagnostic Cable	5 Meters
449 723 018 0	Sensor Extension Cable	1.8 Meters
449 723 030 0	Sensor Extension Cable	3 Meters
449 723 051 0	Sensor Extension Cable	5.1 Meters
449 723 120 0	Sensor Extension Cable	12 Meters
449 723 170 0	Sensor Extension Cable	17 Meters
449 810 148 0	Solenoid Y Cable	3 Meters

Part Number	Nomenclature	Detail
449 811 020 0	Distance Sensor Cable	2 Meters
449 812 100 0	Transducer Cable	10 Meters
480 102 931 2	Cable Clip Repair Kit	1 Large, 1 Small
480 107 000 0	RSSplus™ ECU	4S/2M-2S/2M
884 490 443 0	Tire Inflation I/O Cable	1 Meter
894 590 062 2	LA "Y" Cable	0.4 Meter
894 607 434 0	Stoplight Activation Cable	1 Meter
898 020 462 2	ECU Cable Port Plug	Large
898 020 463 2	ECU Cable Port Plug	Small
899 201 833 4	Power Label	Adhesive
934 099 010 0	Double Check QRV Combination Valve	
934 099 025 0	Select High Double Check Valve	
934 190 008 4	Breather Valve	
TP-95172	ABS Label	Adhesive

Appendix I

Trailer Ground and Protection from Electrostatic Discharge (ESD)

⚠ CAUTION

Unintended voltages induced into the electronic control unit can damage the ECU. Disconnect all connectors from the ECU before you perform any welding, electrostatic painting, or any other activity that applies high voltage to the vehicle frame. Refer to the equipment manufacturer's recommended instructions for correct procedures.

Prevent potential resistance differences in grounding between components (such as axles) and the vehicle frame (chassis).

Make sure that the resistance between metallic parts of the components connected to the trailer frame is less than 10 Ohm (< 10 Ω).

Connect moving or insulated vehicle parts (such as axles) in a electrically conductive manner with the frame.

Ensure a secure and adequate chassis ground at the J560 seven-way connector ground pin on the trailer.

Use electrically conductive bolted connections when fastening the ECUs to the trailer frame.

Welding Work on the Trailer

Disconnect power to the trailer.

Disconnect all cable connections to devices and components and protect the plug-ins and connections from contamination and humidity.

Always connect the grounding electrode directly with the metal next to the welding position when welding, to prevent magnetic fields and current flow via the cable or components.

Make sure that grounding connections are robust by removing paint or rust at the connection points.

Prevent heat influences from the welding activity on devices and cabling when welding.

Note During Electrostatic Painting the Trailer Frame or Bogie

Disconnect all cable connections to devices and components and protect the plug-ins and connections from contamination and humidity.

Dielectric Grease

All Enhanced Easy-Stop ECUs and ECU/valve assemblies with a production date of 1515 or later have NyoGel 760G grease applied. Nyogel 760G is the only grease approved for use on the power, modulator and sensor extension cables of the Enhanced Easy-Stop ABS System. The grease is pre-applied to the ECU sensor O-ring, the power/ modulator cable terminals and the sensor extension cable terminals. Additional grease must not be applied to the ECU's sensor input connectors at a manufacturing or service facility level.

On ECUs manufactured prior to production date 1515, a thin coating of Nyogel 760G can be applied to the 8-pin terminals of the power and modulator cables as well as the male terminal pins on the sensor extension cable. Ensure the greased cables are free from dirt and debris before installation, as the grease readily collects dirt, debris or dust, which may inhibit functionality.

Vehicle Electrical Grounding Guidelines

Ensure that the vehicle includes a correct common chassis ground point. A common chassis ground point connects the trailer frame/ chassis to the ground pin of the J560 seven-way connector and will protect the vehicle electrical system from unwanted electrical noise.

Common chassis ground can be verified by measuring the resistance between the J560 ground pin and the vehicle chassis (or frame) and confirming that the resistance is less than 10 ohm (< 10 Ω). If this is not the case, the electrical contact at the common chassis ground point is not sufficient or not present. If a common chassis ground point is present, but not sufficient, ensure that there is no paint or debris inhibiting electrical contact at the ground point. If a common chassis ground point is not present, WABCO requires adding one. Consult your trailer manufacturer (OEM) for further instructions on how to perform this task. This ensures that the trailer OE warranty is not voided.

NOTE: Do not add more than one common chassis ground point (connecting the J560 ground pin to the chassis) to avoid potential ground shifts within the vehicle electrical system.

Additionally, all standard trailer components, such as axles, should also be electrically connected to the common chassis ground. If the axles are not correctly grounded to the chassis, a ground strap electrically connecting the axle to the chassis must be added to ensure adequate protection from unwanted electrical noise. This can be verified by measuring the maximum resistance between the vehicle chassis/frame and the other trailer component, then confirming that the resistance is less than 10 ohm (< 10 Ω).

For more details concerning correct vehicle grounding, reference SAE standard J1908.

Appendix II

Cable Strain Relief Guidelines

Introduction

It is important that cabling follows good strain relief practices to ensure maximum performance and durability. Failure to provide adequate strain relief on the cables can result in future maintenance that is not covered under warranty.

Strain relief is defined as a small amount of slack in the cable at the area of connection. This lack of cable tension allows for slight movement of the cable during times when components of the suspension and air system are in motion. A small amount of slack also eases access to other system components.

A taut cable can negatively affect the lifespan of the cable and attached component. Cables without adequate strain relief can potentially stress a cable connection enough that moisture could intrude into the cable connector. Internal wire stress at bend points can be the result of a cable under tension.

Cable strain relief is a universal practice. It applies to all WABCO product lines from Anti-Lock Brake (ABS) systems to Roll Stability Systems (RSS).

Excess Cable Length

In cases where the length of cable exceeds what is required, the excess must be bundled in an efficient manner.

- Cables should not be draped or wrapped around components or left unsecured.
- All slack remaining in the cable once the connections are made can be bundled in a Z-shaped loop. Do not coil the cable into a circular bundle.
- The bend at the end of the bundled cable should be greater than or equal to ten times the diameter of the cable.

- All cable fasteners should be tightened in a manner only to the extent that the cable is held sufficiently in place. Over tightening can result in damage to the cable.
- Fasten the excess cable to an area that is free of sharp edges and moving components.

WABCO has many lengths of cables available so it is a best practice to obtain a length that suits the requirements of the installation.

Strain Relief at the ECU – Bracket Mounting

It is recommended that cable connections to a component, such as an ECU valve assembly, display a visible amount of slack in the cable up to the first fastener, that secures the cable to trailer structure or air line. This applies to both zip ties or cable clips. This first anchor point should be a minimum 6-inches and a maximum 12-inches of cable length from the cable/component connection. This applies to all sensor, power, valve and GIO cables. Regardless of whether zip ties or cable clips are used, cables should be secured at intervals of a maximum of 18-inches to avoid cable vibration or excess cable that could potentially snag with external objects.

Ideally, cables should be affixed to the rigid structure of the trailer. It is a requirement to have the bend of the cable, also known as bend radius, be greater than or equal to ten times the diameter of the cable. If the cable is one-quarter-inch in diameter, then the bend should be a minimum of 2-1/2-inches. Figure 84.

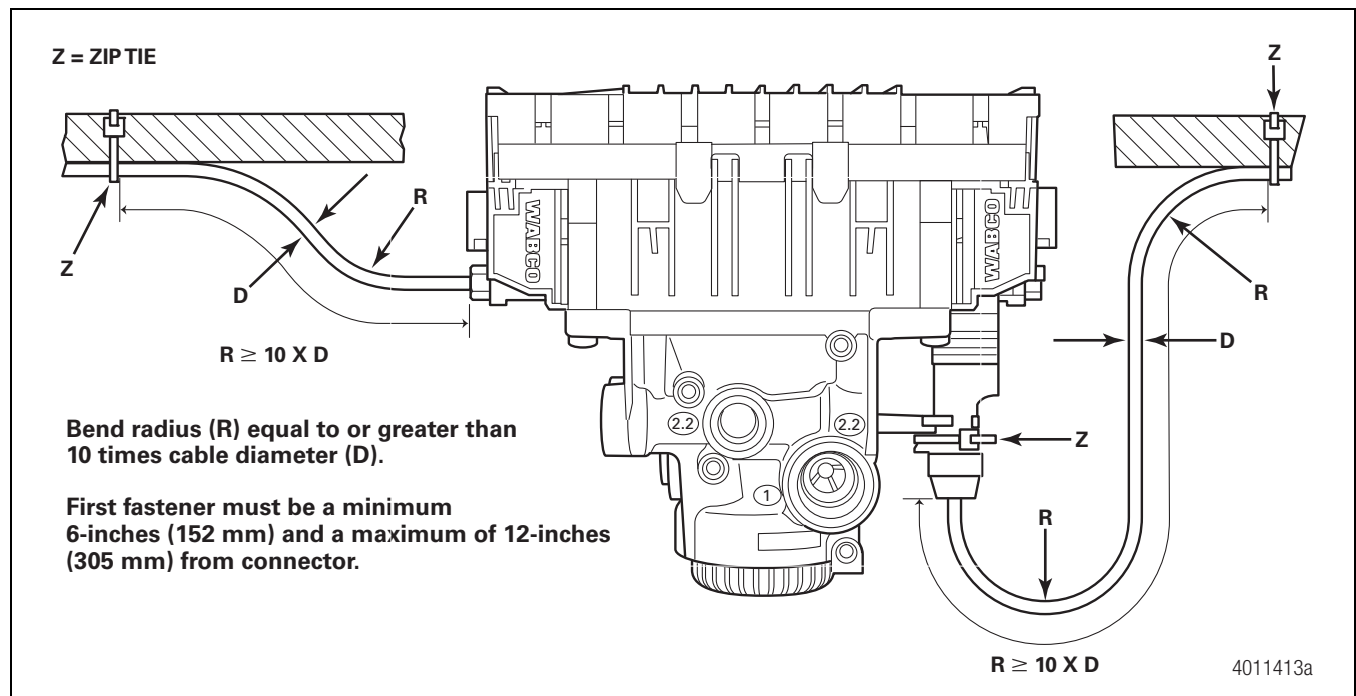

Figure 84

Sensor Extension Cables at the ECU

On valves with no trailer structure nearby, the sensor extension cables are attached to the air lines. Cable clips are preferred to zip ties. It is important to remember that cables should be fastened in a manner where the cable is secured enough where the cable will not move or chafe against what it is mounted to. A small amount of slack should be present to ensure that the cables do not become taut after installation or the servicing of components. Figure 85 illustrates correct amount of slack in the sensor extension cables and correct attachment to the air delivery lines for RSS^{plus} ECUs.

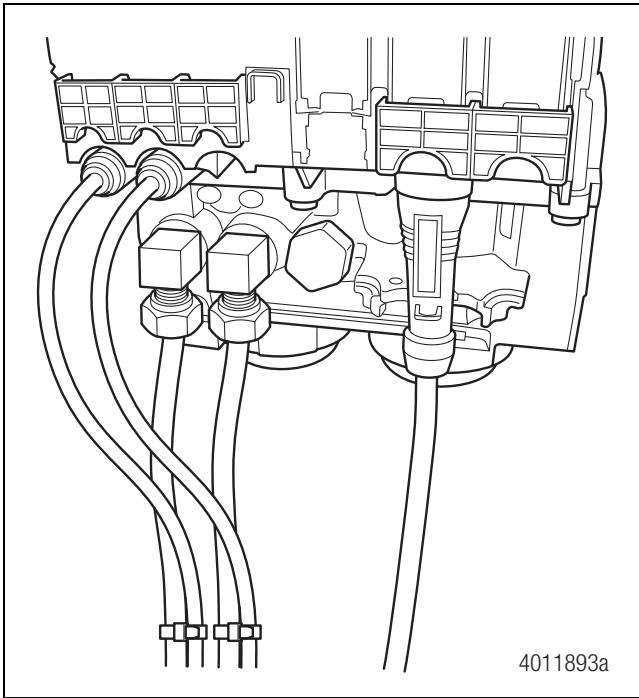
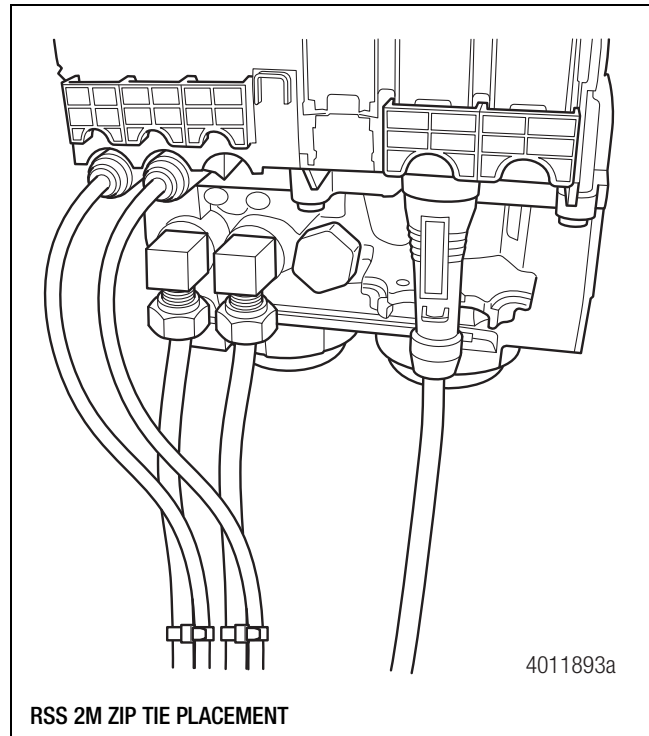

Figure 85

RSS 2M ECU valve assemblies have a zip tie channel on the valve assembly to secure the power cable. Slide the zip tie through the valve assembly's channel and then secure the power cable. When installing a RSS 2M ECU valve assembly, secure the sensor extension cables by fastening them to nearby air lines. It is important to note that an appropriate amount of slack is left in the cables and that cables are secured only to the extent that the cable is held sufficiently in place. Figure 86.



RSS 2M ZIP TIE PLACEMENT

Figure 86

Placement of Cables on Air Lines — Cable-to-Cable Connections

It is important to ensure all cable-to-cable connections maintain good strain relief. Cable restraints must be placed between two- and four-inches (51-102 mm) from the cable connector to ensure correct strain relief. Regardless of whether zip ties or cable clips are used, cables should be secured at intervals not greater than 18-inches (457 mm) to avoid cable vibration. Refer to Figure 87 for air line attachment and Figure 88 for axle attachment.

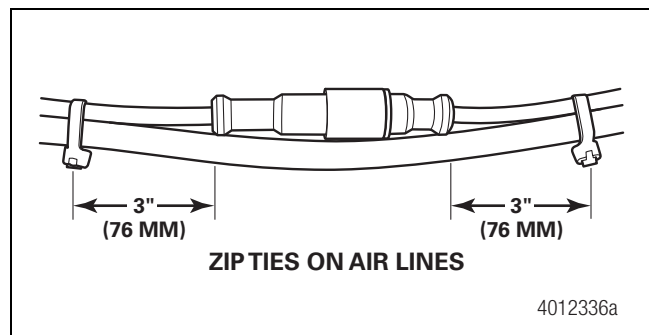

Figure 87

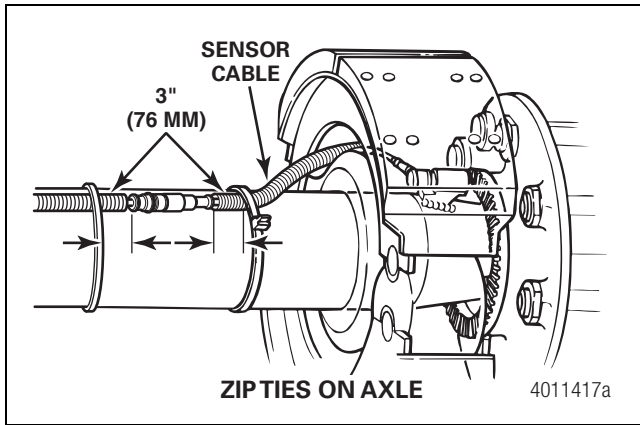

Figure 88

WABCO

WABCO North America
1220 Pacific Drive
Auburn Hills, MI 48326 USA
855-228-3203
wabco-na.com

Information contained in this publication was in effect at the time the publication was approved for printing and is subject to change without notice or liability. WABCO reserves the right to revise the information presented or to discontinue the production of parts described at any time.

Copyright 2018
WABCO, Inc.
All Rights Reserved

Printed in USA

TP-0887
Revised 08-18
(16579)