



# Installing the Meritor WABCO System Saver 1000 and 1200 Series Air Dryers

For Use on Tractors, Trucks  
and Buses with Air Brakes

## Installation Requirements

Item	Qty.	Description
1	1	12- or 24-Volt Air Dryer
2	3	Capscrew (1/2"-13 UNC - 2A x 1.375)
3	3	Lock Washer (1/8" thick)
4	1	Heater Power Harness
5	1	Pressure-Controlled Check Valve

## Service Notes

You must follow your company safety procedures when you install the System Saver 1000 and 1200 Series air dryers. Meritor WABCO uses the following types of notes to give warning of possible safety problems and to give information that will prevent damage to the air dryer.

### **WARNING**

*A warning indicates procedures that must be followed exactly. Serious personal injury can occur if the procedure is not followed.*

### **CAUTION**

*A caution indicates procedures that must be followed exactly. If the procedure is not followed, damage to equipment or components can occur. Serious personal injury can also occur in addition to damaged or malfunctioning equipment or components.*

 *This symbol is used to indicate fasteners that must be tightened to a specific torque value.*

### **NOTE**

*A note indicates an operation, procedure or instruction that is important for correct installation. A note can also give information that will make installation quicker and easier.*

Part Number Selection Guide (See page 3 for application information)			
Series	Voltage (100 Watts)	Replacement Kit	ID Tag Number
1200 Standard Application	12 volts	R955205	432 413 001 0
1200 Standard Application	24 volts	R955206	432 413 002 0
1200E Use with Holset E Compressor	12 volts	R955207	432 413 006 0
1200E Use with Holset E Compressor	24 volts	R955208	432 413 009 0
1200U Discharge Line (Continuous Flow) Installation	12 volts	R955210	432 413 007 0
1200U Discharge Line (Continuous Flow) Unloader Installation	24 volts	R955211	432 413 021 0

## Meritor WABCO System Saver Single Cartridge Air Dryer Publications

- MM34 Maintenance Manual
- PB-96134 Parts Book
- TP-9672 Air Dryer Application Guidelines
- TP-9772 26" x 40" Troubleshooting Guide Wall Chart
- TP-97101 Troubleshooting Guide (laminated card)
- T-97105V Troubleshooting and Repair Video (30 min.)

To order literature contact the Meritor Customer Support Center at 800-535-5560.

## Introduction

This installation manual contains basic installation instructions for standard air systems and includes special instructions for installing the Pressure-Controlled Check Valve (PCCV). It also includes System Saver 1000 and 1200 air dryer diagnostics. Read all instructions before proceeding with your installation.

## Application Information:

Cubic Feet per Minute (CFM)    Less than 25 CFM

Normal Duty Cycle                    Less than 30%

Typical Compressor                    2 Minutes or Less  
Loaded Time

## WARNINGS

**⚠** To prevent serious eye injury, always wear safe eye protection when you perform vehicle maintenance or service.

**⚠** Do not work around or under the vehicle unless it is parked on a level surface. Use blocks to keep the vehicle from moving. A moving vehicle can cause serious personal injury and damage.

**⚠** Remove all air from the air system before servicing any component in the air system. Pressurized air can cause serious personal injury.

## Basic Installation Instructions

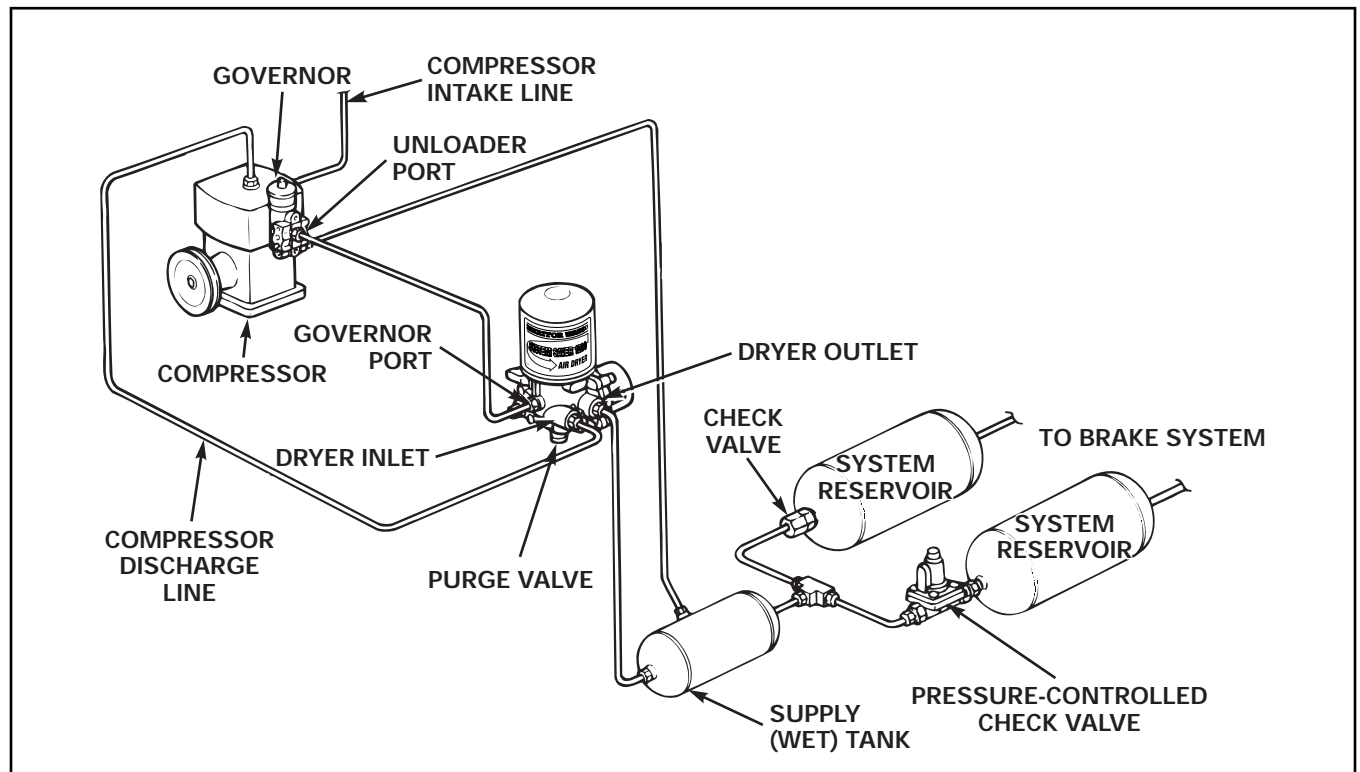

TYPICAL INSTALLATION FOR SYSTEM SAVER 1000 AND 1200 SERIES AIR DRYER

## Mounting the Air Dryer

1. Park the vehicle on a level surface, stop the engine, set the parking brake and block the wheels.
2. Drain pressurized air from **all reservoirs** to 0 psi (0 bar). Open **all** draincocks to expel collected water.
3. Inspect the vehicle for a suitable mounting location that meets the following criteria. The air dryer will operate most efficiently when you follow these guidelines.
  - a. Mount the air dryer where cool air can flow around it . . . but not directly in the vehicle wind stream . . . and at least 12 inches away from any heat source.
  - b. Mount the air dryer **LOWER** than the compressor so that water in the delivery line flows into the air dryer. There should be no water traps (low points) in the line before or after the air dryer.
  - c. Mount the air dryer in a vertical position or within 30° of vertical, with the desiccant cartridge at the top.
  - d. Allow at least two inches (51 mm) of clearance above the top of the air dryer for servicing the desiccant cartridge.
  - e. Mount the air dryer in a location where it is not subject to direct splash or spray from a wheel.
4. Apply the adhesive-backed template to the selected location. **Figure 1**.

Figure 1

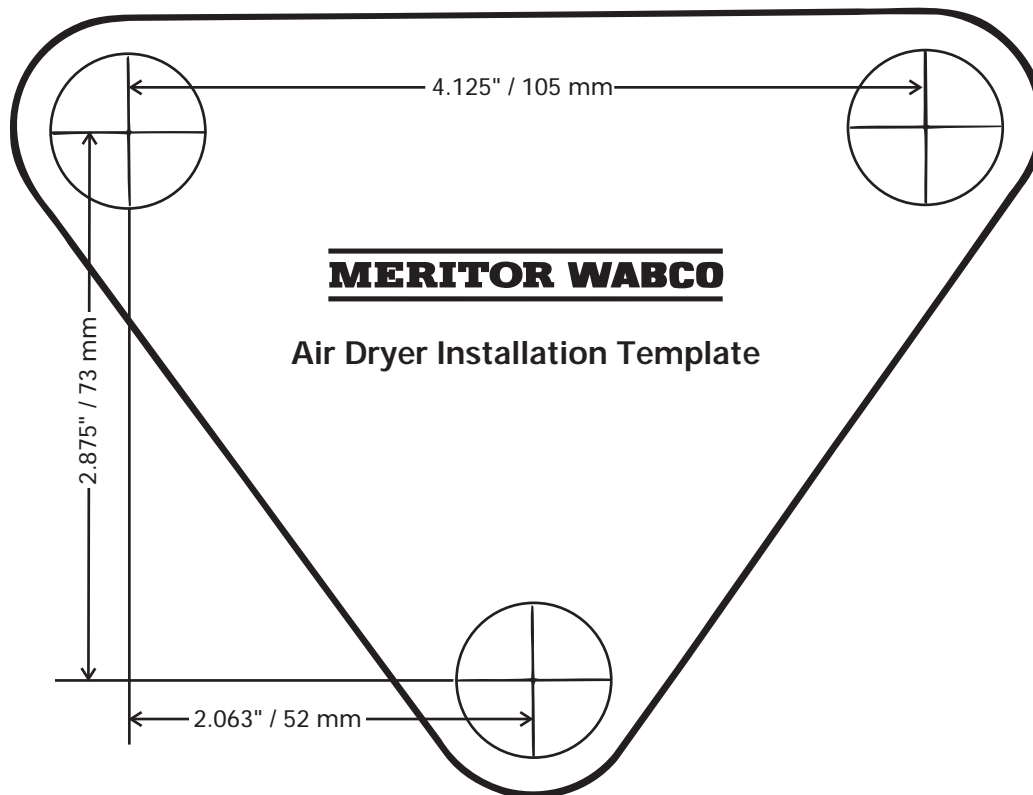

## NOTE

Check the vehicle manufacturer's specifications before drilling into the frame member.

5. Drill 9/16-inch holes at each cross mark. Use a mounting bracket, if necessary. **Figure 2** or **3**.
6. Mount the air dryer using the capscrews and lock washers provided.
7. Tighten each capscrew to 22-30 lb-ft (30-40 N•m). **T**

**Figure 2**

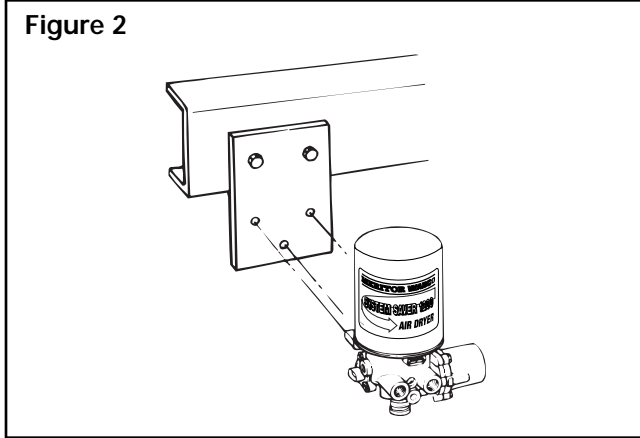

**Figure 3**

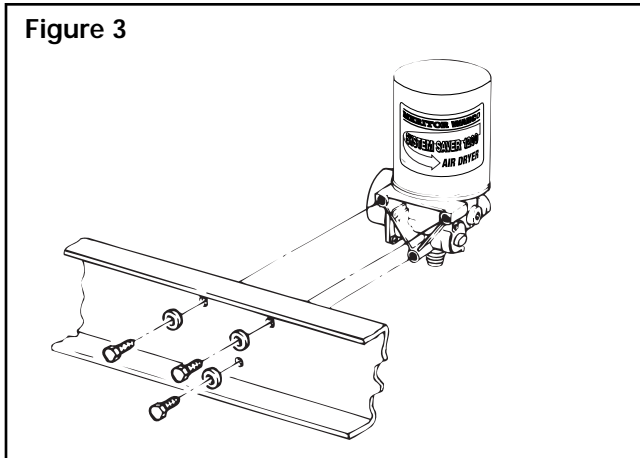

## Connecting the Air Lines

### NOTE

Use pipe sealant or teflon tape on all air fittings.

### NOTE

The reference to nylon tubing throughout this manual refers to SAE J844 air brake nylon tubing.

1. Connect the delivery line from the compressor to the air dryer inlet port (1/2" NPTF, marked "1") with 1/2-inch-ID minimum stainless-steel braided teflon hose. The air dryer will operate most efficiently when the following guidelines are used.
  - a. The delivery line should follow a **DOWNHILL** route to the inlet port (**Figure 4**), free of kinks and sags, which cause water traps.

**Figure 4**

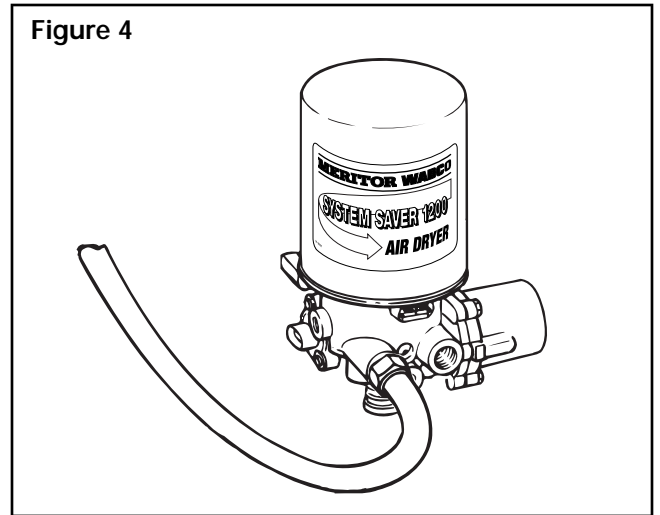

- b. Air temperature entering the dryer should be less than 175°F (79.5°C). The delivery line must be at least 6.0 feet (1.83 m), but most vehicles require a greater length to achieve this condition.
- c. The delivery line should not exceed 20 feet (6.1 m), or moisture within the line can freeze, blocking air passage.
- d. Insulate a delivery line with a length of over 10 feet (3.0 m).

2. Connect the air dryer outlet port (1/2-inch NPTF, marked "21") to the inlet of the supply (wet) tank with 1/2-inch or 5/8-inch nylon tubing. **Figure 5.**
3. Connect the air governor unloader port to the air dryer control port (1/4-inch NPTF, marked "4") with 1/4-inch or 3/8-inch nylon tubing. **Figure 6.**
4. Check all fittings for leaks before proceeding.

**Figure 5**

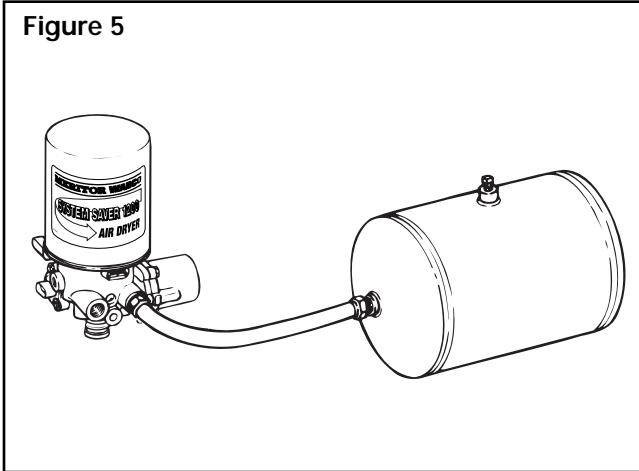

**Figure 6**

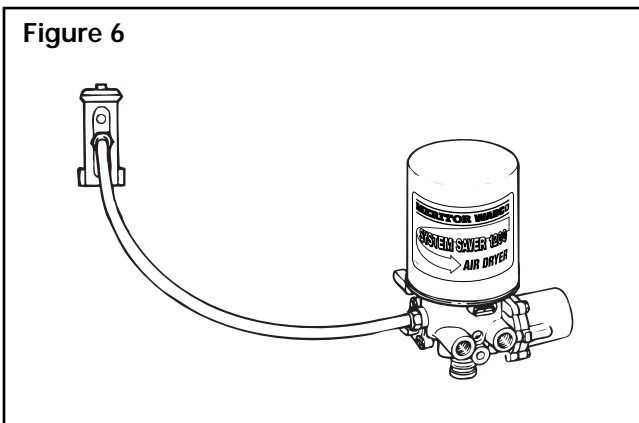

## Connecting the Heater

The System Saver 1000 and 1200 Series air dryers are available in 12- or 24-volt models; each has a 100-watt heater. Each kit contains a two-wire harness which supplies power to the unit. Be sure to select the correct power source for the air dryer model. Using the wrong voltage can cause malfunction and even damage the unit. Check vehicle manufacturer specifications for exact wiring information.

1. Connect one of the leads to a good vehicle ground. Attach the other lead to a line that is powered with the ignition in the run position, and not powered with the ignition off. A 15-amp fuse is recommended for this line for 12 volts and 7.5 amps for 24 volts.
2. Press the male plug on the end of the power cable into the receptacle on the side of the dryer. Plug must be inserted until the latch snaps over the tab on the mating connector. **Figure 7.**
3. Insulate and seal all electrical splices and properly secure the harness.

**Figure 7**

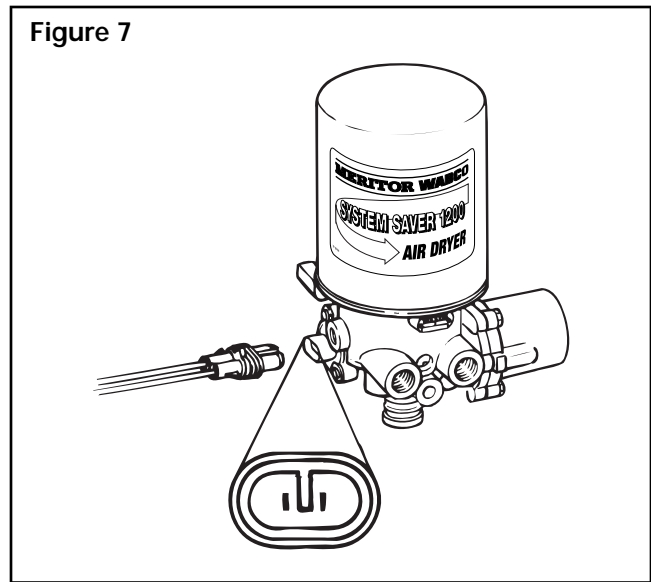

## Determine the Correct Pressure-Controlled Check Valve (PCCV) Placement for the System Saver 1000 and 1200 Series Air Dryer

The regeneration volume is determined by how much compressed air is pumped through the air dryer during each compressor cycle. The following chart shows the proper sizing of the system and the volume of the reservoirs contributing to the regeneration volume required for a given installation. The "reservoirs contributing to regeneration" will determine the placement of the PCCV in the system. Since the air dryer will take approximately 10 psi from the contributing reservoirs, the volume for regeneration will be a function of the reservoir sizes.

The "Total System Size" is the sum of all the air tanks to be filled on all vehicles that the compressor will be filling. For instance, if the tractor has a total air system of 6000 in<sup>3</sup> (supply — 900 in<sup>3</sup>, primary 3200 in<sup>3</sup>, secondary 1900 in<sup>3</sup>) and it pulls a lead single trailer with 1400 in<sup>3</sup>, a single axle dolly with 1400 in<sup>3</sup>, and a second single axle trailer with 1400 in<sup>3</sup>, the total system size is 10,200 in<sup>3</sup>. Looking at the chart and finding 10,200 in<sup>3</sup> at the bottom, reading up and over shows the system needs 2856 in<sup>3</sup> of reservoir volume contributing to regeneration. From this volume, ≈ 10 psi would be taken for regeneration. In this case, installing the PCCV on the primary tank gives adequate regeneration volume (supply 900 in<sup>3</sup> + primary 3200 in<sup>3</sup> = 4100 in<sup>3</sup>). **Figure 8.**

## Formula for Total System Size

Use the formula below to compute total system size.

- **Total System Size = Sum of all reservoir tanks an air compressor must service in the vehicle's air system.**

**Example:**

	(IN <sup>3</sup> )
• Supply (Wet) Tank	900
Primary Reservoir Tank	3200
Secondary Reservoir Tank	<u>1900</u>
Tractor's Total Air System	6000
	(IN <sup>3</sup> )
• Lead Single Axle Trailer	1400
Single Axle Dolly	1400
Second Single Axle Trailer	<u>1400</u>
Total Load Pulled:	4200
• Total Combination Vehicle System Size (IN <sup>3</sup> )	
The Air Compressor Must Service	6000 + 4200 = <u>10,200</u>

**Figure 8**

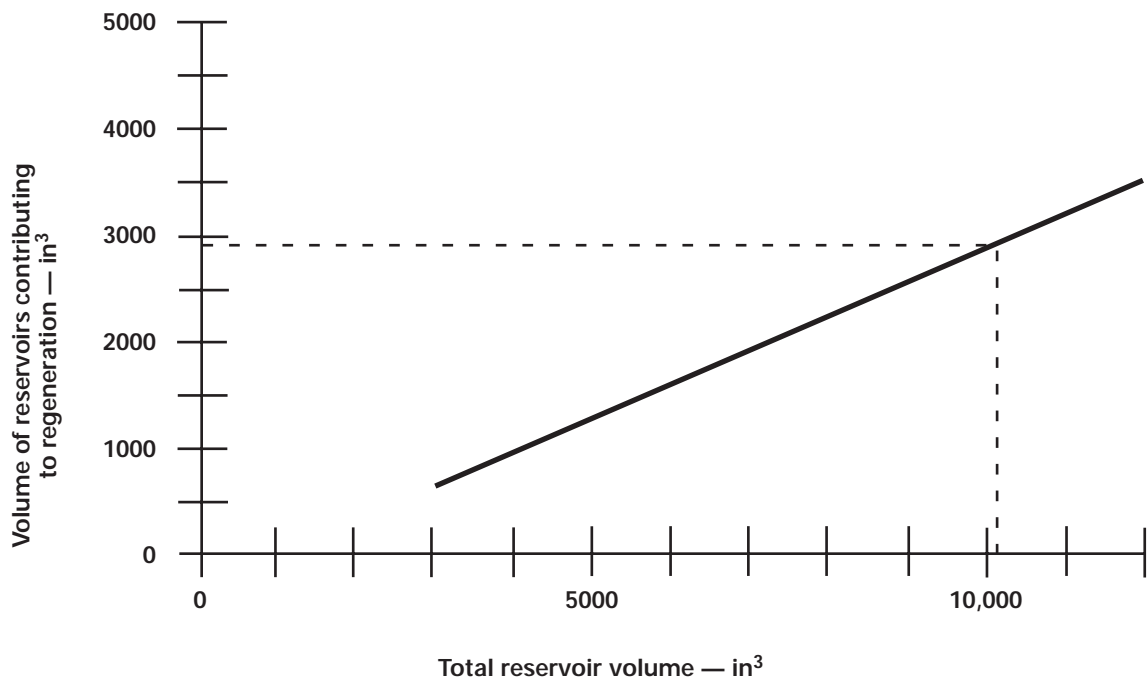

## Installing the Pressure-Controlled Check Valve (PCCV)

### NOTE

The pressure-controlled check valve replaces the one-way check valve on either the secondary or primary service reservoir. Use pipe sealant or teflon tape on all air fittings.

1. Identify the appropriate service reservoir (see above) and locate the one-way check valve at the inlet. This reservoir is fed by the supply (wet) tank and typically supplies air to the front brakes and air-operated accessories. For more information about the PCCV, please refer to TP-9672, *Air Dryer Application Guidelines*.

### NOTE

If the one-way check valve is internal or otherwise inaccessible, locate the check valve on the primary reservoir.

2. Remove and **discard** the one-way check valve from the reservoir.

### NOTE

The arrow located on the face plate of the PCCV must point **TOWARD** the reservoir. *Figure 9.*

3. Install the pressure-controlled check valve in place of the check valve you discarded. If space is limited, you can use a 45° or 90° pipe fitting.
4. Reconnect the supply line from the supply (wet) tank to the inlet of the PCCV. Reroute or shorten the air hose as necessary.

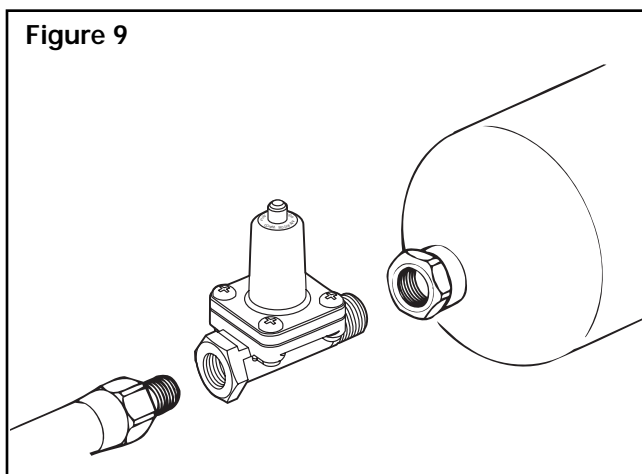

Figure 9

## Check the Vehicle's Air System for an Alcohol Evaporator

### NOTE

Typically, an alcohol evaporator will be installed in the line between the air dryer and the supply (wet) tank. Common installations are on the truck's firewall, on a frame rail and behind the cab. However, an alcohol evaporator can also be found at other locations.

1. Check the vehicle's air system to determine if an alcohol evaporator is installed.
2. If an alcohol evaporator is installed in the air system, check for a bypass line connected to the evaporator, as illustrated in **Figure 10**.

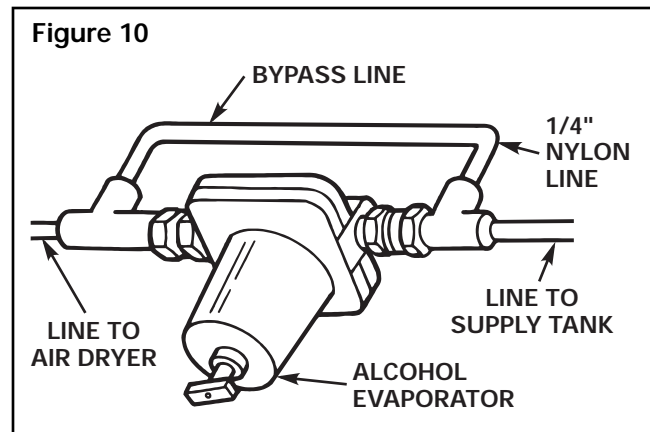

Figure 10

### CAUTION

If a check valve is installed in the bypass line, the air dryer will not function properly. Damage to the system can result.

3. If a bypass line is connected to the evaporator, check to see if a check valve is installed in the bypass line. If check valve is installed:
  - a. remove the check valve from the bypass line,
  - b. remove the bypass line and
  - c. replace the bypass line with 1/4-inch nylon line.
4. If there is no bypass line installed at the alcohol evaporator, install one using 1/4-inch nylon line. **Figure 10.**



## Testing the System Saver 1000 and 1200 Series Air Dryers

1. Close the drain cocks on all reservoirs.
2. Start the vehicle. Wait for the air system to reach full operating pressure.
3. If the air dryer exhausts air for 10-20 seconds after the governor cuts out, it is working correctly.
4. Apply vehicle brakes several times until the compressor cuts in.
5. If the air dryer exhausts air for 10-20 seconds after the compressor cuts out, it is working correctly.

### **NOTE**

*One of the air pressure gauges on the vehicle instrument panel will decrease by approximately 10 psi when the compressor cuts out and the air dryer purges. This decrease is normal for the System Saver 1000 and 1200 Series air dryers. If the gauge does not decrease, recheck the plumbing to ensure proper placement of the pressure-controlled check valve.*

## Final Checks

1. Start the vehicle. Wait for the air system to reach full operating pressure. When the compressor cuts out, listen to the air dryer. If either of the following conditions exist, refer to Meritor WABCO Maintenance Manual No. 34, *System Saver 1000 and 1200 Series Air Dryers*.
  - a. The air dryer continues to exhaust air for longer than 30 seconds.
  - b. The air dryer does not exhaust air after initial decompression.
2. Shut engine **OFF**. Apply a soap solution to each connection that contains pressurized air:
  - a. If soap bubbles do not appear, connections are sealed properly.
  - b. If soap bubbles appear:
    - Drain all reservoirs.
    - Remove leaking connection.
    - Inspect for damaged threads or cracks; replace as necessary.
    - Apply pipe sealant or teflon tape to the connection.
    - Repeat process.



## System Saver 1000 and 1200 Series Air Dryers Diagnostics

Condition	Possible Cause	Solution
Dryer leaks from purge valve during compressor loaded cycle. The leak may cause excessive compressor cycling or prevent the system from building air pressure.	<p>Purge valve frozen open (cold weather operation).</p> <p>Debris under purge valve seat, such as particles from fittings or air inlet line.</p> <p>Purge valve washer installed upside-down.</p> <p>Wrong air line connected to dryer port 4 (unloader port).</p> <p>Purge valve snap ring not fully seated in groove.</p>	<p>Check heater. Repair/replace if necessary. Make sure governor to dryer port 4 line is free of water/oil.</p> <p>Remove and inspect purge valve and clean water/oil from top of piston.</p> <p>Disassemble and clean purge valve.</p> <p>Remove cartridge and clean dryer sump area.</p> <p>Ensure lip on aluminum washer faces <b>down</b>, away from dryer.</p> <p>Verify correct air line installation and correct as needed.</p> <p>Seat snap ring fully into groove.</p>
Slight leak from purge valve. After several hours, the supply tank may be empty.	Outlet check valve not seating or regeneration valve not shutting off regeneration airflow.	Remove, inspect, and clean outlet check valve and regeneration valve diaphragm. Replace if worn or damaged.
Regeneration cycle too long (more than 30 seconds), accompanied by loss of pressure in the supply tank.	<p>Outlet check valve not seating.</p> <p>Regeneration valve not shutting off regeneration airflow.</p>	<p>Inspect and replace outlet check valve as needed.</p> <p>Replace regeneration valve.</p>
Regeneration cycle too short (less than 10 seconds).	<p>High air system demands during compressor unloaded cycle.</p> <p>Pressure-controlled check valve not installed in system or not working properly.</p> <p>One-way check valve installed in system reservoir instead of, or with, pressure-controlled check valve.</p> <p>Regeneration valve not working.</p> <p>Air governor not working properly.</p>	<p>Increase air system capacity or reduce air demands.</p> <p>Check and replace pressure-controlled check valve as needed.</p> <p>Remove one-way check valve. Make sure pressure-controlled check valve is installed correctly.</p> <p>Remove regeneration valve and clean oil from diaphragm. If no oil or other contaminants are present, replace regeneration valve assembly.</p> <p>Inspect per manufacturer's instructions and repair/replace as needed.</p>
No regeneration cycle. No airflow from purge valve after initial purge blast (dryer decompression).	<p>Air dryer not connected to supply tank or connections reversed at dryer.</p> <p>Regeneration valve not working.</p> <p>One-way check valve installed in supply tank.</p> <p>Alcohol evaporator installed between dryer and supply tank.</p>	<p>Verify proper dryer installation per system diagram.</p> <p>Replace regeneration valve.</p> <p>Remove one-way check valve.</p> <p>Install bypass line around evaporator or remove evaporator from system.</p>
Air dryer purges too often, perhaps as frequently as every 15 seconds, accompanied by excessive cycling of the compressor.	<p>Leak in line between governor and dryer port 4.</p> <p>Leak in line between supply tank and governor.</p> <p>Excessive air system leaks.</p> <p>Excessive air system demands.</p> <p>Outlet check valve not sealing.</p> <p>Regeneration valve not shutting off properly.</p> <p>Air governor has less than 16 psi range.</p> <p>Leaking air compressor unloader(s).</p>	<p>Repair air line.</p> <p>Repair air line.</p> <p>Repair leaks.</p> <p>Increase air system capacity or reduce air demand.</p> <p>Inspect and replace outlet check valve as needed.</p> <p>Replace regeneration valve.</p> <p>Replace air governor.</p> <p>Inspect compressor. Repair/replace per manufacturer's instructions.</p>
Air dryer does not purge when compressor unloads (no blast of air from purge valve).	<p>Air line between governor and air dryer port 4 kinked or plugged.</p> <p>Purge valve stuck closed.</p> <p>Air governor not working properly.</p> <p>Cut-out pressure never achieved by air compressor.</p>	<p>Repair air line.</p> <p>Replace purge valve.</p> <p>Inspect air governor. Repair/replace per manufacturer's instructions.</p> <p>Check for air leaks in system and repair as needed. If no leaks in system, check compressor output. Repair/replace per manufacturer's instructions.</p>
Air flows out of purge valve entire time compressor is unloaded.	Turbo cut-off valve not sealing.	Replace turbo cut-off valve.

## System Saver 1000 and 1200 Series Air Dryers Diagnostics (Continued)

Condition	Possible Cause	Solution
Rapid "spitting" of air from purge valve in small amounts. Frequency varies with engine speed.	Holset E-Type compressor used, but non-1200E dryer installed. Compressor not completely unloading when cut-out pressure is reached.	Replace air dryer with a System Saver 1200E air dryer. Inspect compressor. Repair/replace per manufacturer's instructions.
Air leak at turbo cut-off valve vent. Hole burned in piston.	Temperature of air coming into dryer is too high – not enough cooling takes place before dryer inlet.	Move dryer farther from compressor. Add additional compressor discharge line before air dryer. Add cooling coil or heat exchanger before air dryer. <b>NOTE: Inlet air temperature must not exceed 175°F.</b>
Air leak at turbo cut-off valve vent.	Lip seal installed upside-down on piston. Lip must face <b>UP</b> (towards dryer). Valve bore worn excessively.	Install lip seal correctly. Inspect valve bore for wear. If a new turbo cut-off valve does not seal in a clean, lubricated bore, replace the air dryer.
Air dryer frozen (water collecting in base of dryer is freezing).	No electrical power to heater connector.  Low voltage to heater connector.  Heater assembly not working.  Wrong voltage air dryer used; i.e., 12-volt air dryer used in a 24-volt system.	Check for a blown fuse. Repair heater circuit. <b>NOTE: There must be power to the heater connector the entire time the vehicle's ignition is "on."</b> Repair cause of low voltage, such as poor electrical ground, bad connections, corroded wire splices, etc. Replace heater assembly. Replace with correct voltage air dryer.
No air pressure build-up in system.	Air dryer not plumbed correctly (connections reversed).  Wrong air line connected to dryer port 4.  Air governor not working properly.  Air system leaks, such as compressor discharge line, air dryer, reservoirs, brake or suspension valves, etc.  Air dryer leaks from purge valve.	Ensure compressor discharge line is plumbed to air dryer port 1, and air dryer port 21 is connected to vehicle's supply tank.  Ensure dryer port 4 line is connected to the "UNL" port of the air governor. Inspect governor per manufacturer's instructions. Repair or replace as needed. Locate leak(s) and repair.  See purge valve conditions listed in this chart.
Water in tanks; often following aftermarket installation or when dryer is a replacement for a competitive brand.	Pressure-controlled check valve not installed in correct tank or not installed at all. Pressure-controlled check valve properly installed, but one-way check valve not removed.	Install pressure-controlled check valve in secondary tank. Remove one-way check valve so that only the pressure-controlled check valve is installed between the secondary tank and supply tank.
Water, oil, or sludge in air system tanks.	Desiccant contaminated with oil.  Holset E-type compressor used, but non-1200E dryer installed.	Replace desiccant. Inspect compressor per manufacturer's instructions. Replace air dryer with a System Saver 1200E air dryer.
Water in system tanks, everything else checks out okay.	Dryer not suitable for application.	Review application guidelines. For assistance, call Meritor Customer Support Center at 1-800-535-5560.

# MERITOR WABCO

**Meritor WABCO**  
**Vehicle Control Systems**  
 2135 West Maple Road  
 Troy, MI 48084 U.S.A.  
 800-535-5560  
 www.meritorauto.com

Information contained in this publication was in effect at the time the publication was approved for printing and is subject to change without notice or liability. Meritor WABCO reserves the right to revise the information presented or discontinue the production of parts described at any time.

© Copyright 1998  
 Meritor WABCO  
 All Rights Reserved

Printed in the USA  
 Please Recycle

TP-92116  
 Revised 8-98  
 16579/Meritor