

# Installation Instructions GOOSENECK MOUNTING KIT

**Part Numbers:**

**4448**

**Ford F-250/F-350 Super Duty**

Will not fit Cab-on-Chassis vehicles

**WARNING:** Under no circumstances do we recommend exceeding the towing vehicle manufacturers recommended vehicle towing capacity.

**Equipment Required:**

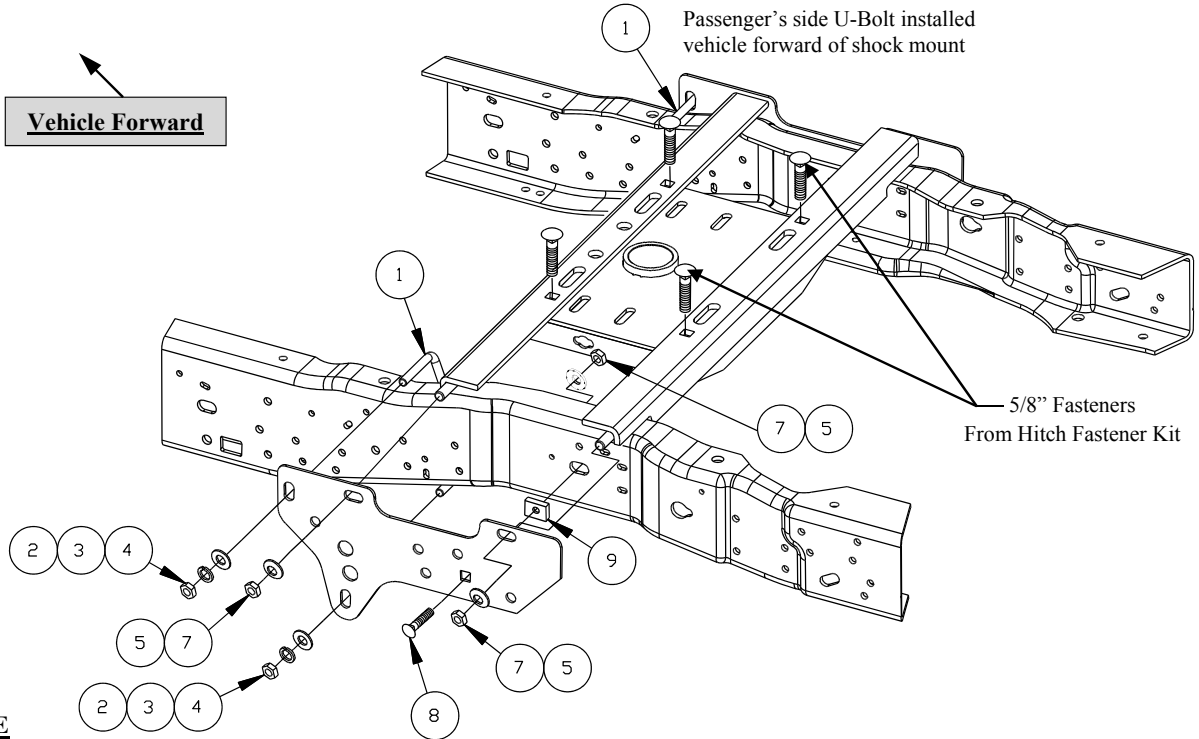
**Fastener Kit:** 4448F

**Wrenches:** 7/16", 9/16", 5/8", 11/16", 3/4",  
15/16", 13 mm

**Drill Bits:** 1/4"

**Other Tools:** Drill

## 9460/9470 HIDE-A-GOOSE HITCH INSTALLATION



**NOTE**

- **Vehicle bed cross-members not shown for clarity.**
- **All holes and slots typical on both sides of vehicle.**

**Figure 1**

1	Qty. (2)	U-Bolt, 1/2-13	11	Qty. (2)	Flat Washer, 1/4
2	Qty. (4)	Flat Washer, 1/2	12	Qty. (1)	Nylock Nut, 1/4
3	Qty. (4)	Lock Washer, 1/2	13	Qty. (1)	Hex Bolt with Washer, M8 X 1.25 X 35mm
4	Qty. (4)	Hex Nut, 1/2	14	Qty. (2)	Hex Nut, M8
5	Qty. (6)	5/8 Conical Toothed Washer	15	Qty. (2)	Conical Washer, 3/8
6	Qty. (1)	Cable Tie (not shown)	16	Qty. (2)	Spacer, 3/8 X 1.50 X 2.00
7	Qty. (6)	Hex Nut, 5/8	17	Qty. (2)	Locknut, 7/16-14
8	Qty. (2)	Carriage Bolt, 5/8-11 X 2.50 GR5	18	Qty. (2)	Hex Bolt, 7/16-14 X 1.50
9	Qty. (2)	Block, 5/8 X 1.50 X 2.00	19	Qty. (4)	Shims, 1/4 X 2.00 X 1.00
10	Qty. (1)	Hex Bolt, 1/4-20 X 1.25			

# Installation Instructions

## GOOSENECK MOUNTING KIT

Part Numbers:

**4448**

### Ford F-250/F-350 Super Duty

Will not fit Cab-on-Chassis vehicles

**NOTES:**

- This rail kit can be used with a 9460 or 9470 head only.
- Always make sure the ball is fully locked before towing.
- Keep the ball and ball sleeve well lubricated.
- Periodically re-torque all the hitch fasteners.
- Check ball, hitch coupler, safety chains and other connections for proper operation every time you tow.

**Warning:**

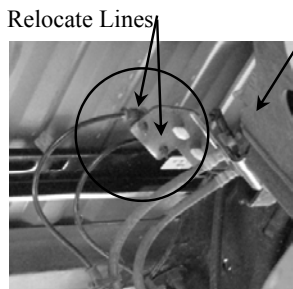
- ❖ The tow vehicle manufacturers recommended towing capacities should UNDER NO CIRCUMSTANCES be exceeded.
- ❖ Check for adequate clearance between the gooseneck trailer and the rear of the cab and the rear of the truck box before installing hitch.
- ❖ All trucks have fuel lines, brake lines and electrical wiring located along the vehicle frame where the rail kit installs. Carefully examine the location of fuel lines, brake lines and electrical wires before installation and be certain not to damage these when positioning the hitch components. Be careful when drilling holes, cutting sheet metal and tightening fasteners as to not limit the integrity of these systems.

**Hide-A-Goose Only – Drilled hole in bed location (see step 8).**

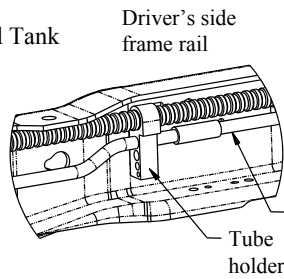
**Short Box & Long Box – 46-3/16 inches**

**Hide-A-Goose Installation Instructions**

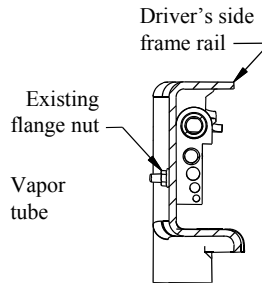
1. Lower the vehicle exhaust.
2. Use the provided cable tie to relocate the lines connected to the bracket on the driver's side of the vehicle, shown in Figure 2a.
- 2b. **On Gas Engine Vehicles Only.** The vapor tube running along the inside of the driver's side frame rail must be relocated prior to installing the driver's side bracket (see Figure 2b). Remove the flange nut from the outside of the frame and keep for later use (see Figure 2c). Rotate the tubes up and out of the way. Install the L-bracket with 1/4" hardware, as shown in Figure 2d. Tighten the L-bracket to the frame, but leave the tube holder loose to aid bracket installation. The tube holder will be tightened onto the L-bracket in Step 12.



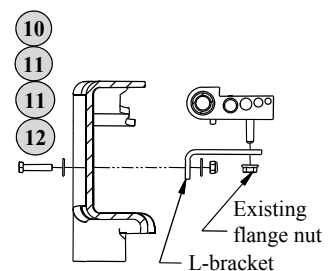
**Figure 2a**



**Figure 2b**  
Inside of frame rail

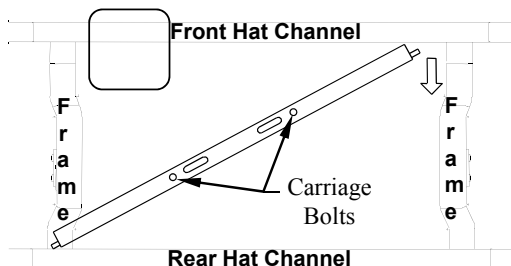


**Figure 2c**

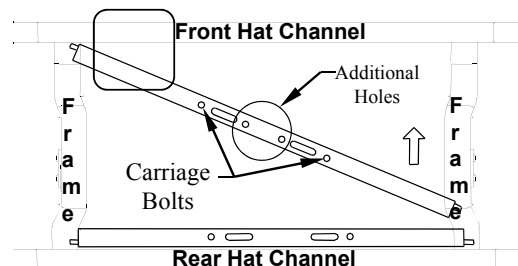


**Figure 2d**

3. Place 5/8" GR8 carriage bolts from the 9460/9470 fastener kit into the square holes on the forward and rearward cross members from the top pointing towards the ground. The forward cross member has two additional holes (see figure 3).
4. From underneath the vehicle, install the **rearward** hitch cross member by placing one end above the vehicle frame and maneuvering the notched section of the opposite end, above the vehicle frame. Temporarily position the rearward hitch cross member against the rear hat channel of the vehicle.
5. From underneath the vehicle install the **forward** hitch cross member by placing the driver's side notched end above the vehicle frame and maneuvering the opposite notched end above the exhaust and above the vehicle frame.



**Rear Cross Member  
Installation**



**Forward Cross Member  
Installation**

**Figure 3**

# Installation Instructions

## GOOSENECK MOUNTING KIT

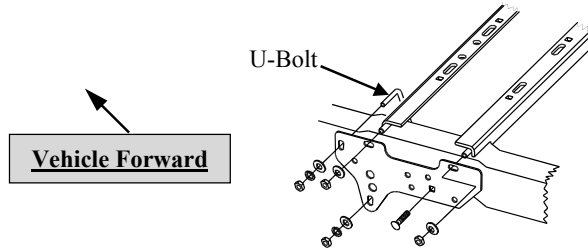
Part Numbers:

4448

### Ford F-250/F-350 Super Duty

Will not fit Cab-on-Chassis vehicles

- Loosely install the driver's side and passenger's side hitch side brackets by attaching the 5/8" hardware to the threaded studs. Install the 5/8 X 2.50 carriage bolts through the hitch side brackets, 5/8" blocks and the large slots in the vehicle frame rails. Loosely, install the 5/8 Conical Toothed Washers and 5/8 hex nuts to the carriage bolts (see Figure 1).
- Use the supplied U-Bolt for the forward attachment of the bracket to the frame (see Figure 4). Position the U-Bolt from the inside of the vehicle frame pointing towards the hitch side bracket. On the passenger's side of the vehicle, the U-Bolt must be positioned to the vehicle forward side of the shock mount and installed on an angle through the mounting slots on the hitch side bracket.

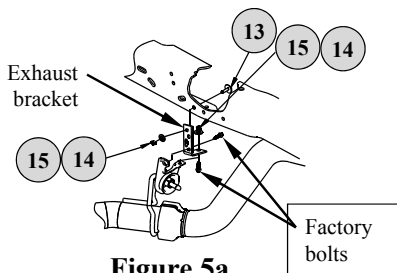


**Figure 4**

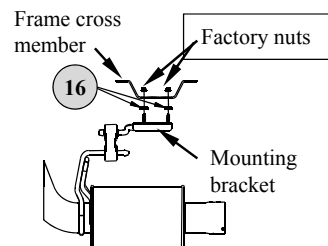
- When installing the 9460/9470 Hide-A-Goose hitch, a hole must be drilled in the bed of the truck. Mark and drill a 1/4 inch hole 46-3/16 inches (**short & long box**) from the rear of the bed and centered between the wheel wells. Using a hole saw enlarge the pilot hole to final diameter hole size. Refer to the 9460/9470 Hide-A-Goose hitch instruction sheet for hole size.
- Loosely install the 9460/9470 Hide-A-Goose hitch. Refer to the 9460/9470 instruction sheet for fasteners and locations.
- After loosely installing the Hide-A-Goose hitch and 4448 mounting kit, line up the hitch ball sleeve with the opening in the truck bed. Torque all 5/8-11 GR5 fasteners to 150 ft.-lb. (203 N-m), 1/2-13 GR5 fasteners to 75 ft.-lb. (102 N-m), and 5/8-11 GR8 fasteners on the hitch to 212 ft.-lb. (287 N-m). Use the following sequence: a) torque frame brackets to the frame of the vehicle, b) torque cross members to the frame brackets, c) torque hitch to cross members.
- On Gas Engine Vehicles Only** Use the factory flange nut that was removed in Step 2 to tighten the tube holder onto the L-bracket as shown in Figure 2d.
- On some vehicles the Hide-A-Goose handle may contact the emergency brake cable. The brake cable bracket should be adjusted to provide clearance.
- Reinstall exhaust as shown below.

#### Exhaust installation:

- If there is less than 1/2" clearance between the exhaust pipe and the Hide-A-Goose cross members, the exhaust bracket supplied with the 4448 mounting kit must be used (See figure 5a and 5b). For the rear attachment (Figure 5a), fasten the supplied bracket extension to the factory bracket with the factory M8 bolts, then fasten the extension to the frame with the supplied hardware. Reattach the exhaust bracket forward of the axle to the frame cross member with 3/8" spacers sandwiched between the bracket and cross member.



**Figure 5a**  
Rear Attachment



**Figure 5b**  
Center Attachment

# **Installation Instructions**

## **GOOSENECK MOUNTING KIT**

**Ford F-250/F-350 Super Duty**

Will not fit Cab-on-Chassis vehicles

**Part Numbers:**

**4448**

**This page was intentionally left blank.**

# Installation Instructions

## GOOSENECK MOUNTING KIT

Part Numbers:

**4448**

### Ford F-250/F-350 Super Duty

Will not fit Cab-on-Chassis vehicles

**Equipment Required:**

**Fastener Kit:** 4448F

**Wrenches:** 7/16", 9/16", 5/8", 11/16", 3/4",  
15/16", 13 mm

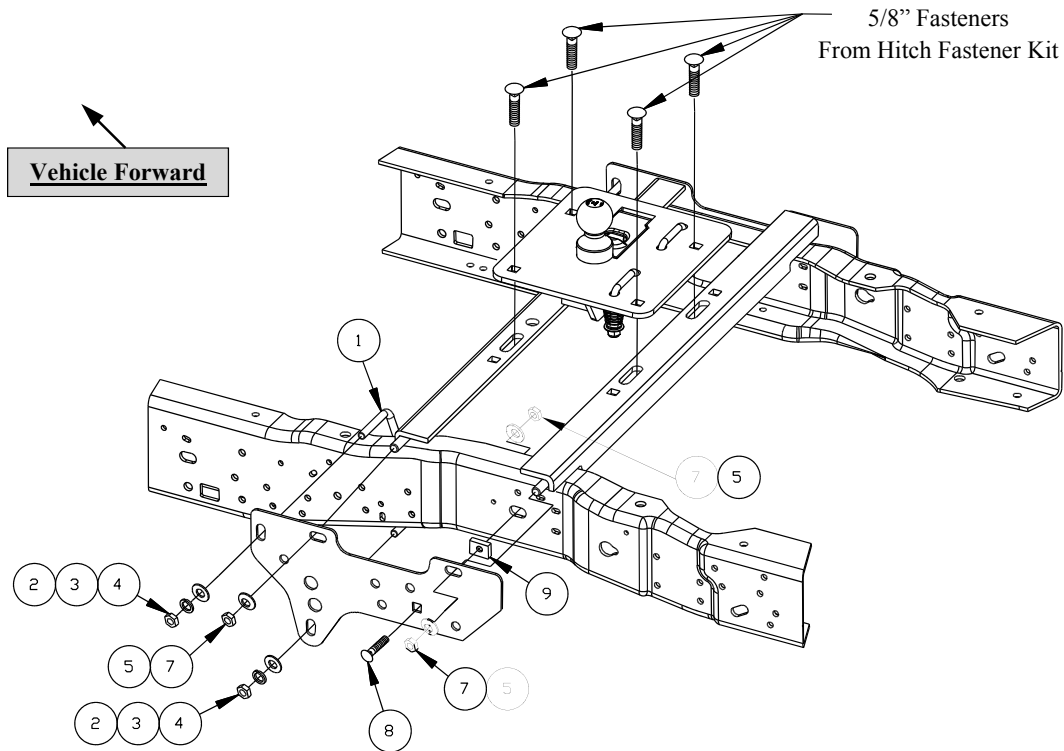
**Drill Bits:** 1/4"

**Other Tools:** Drill

**WARNING:** Under no circumstances do we recommend exceeding the towing vehicle manufacturers recommended vehicle towing capacity.

## 6300/8339/83391/83399 GOOSENECK HITCH

### INSTALLATION



**NOTE**

- **Vehicle bed cross-members not shown for clarity.**
- **All holes and slots typical on both sides of vehicle.**

**Figure 1**

1	Qty. (2)	U-Bolt, 1/2-13	11	Qty. (2)	Flat Washer, 1/4
2	Qty. (4)	Flat Washer, 1/2	12	Qty. (1)	Nylock Nut, 1/4
3	Qty. (4)	Lock Washer, 1/2	13	Qty. (1)	Hex Bolt with Washer, M8 X 1.25 X 35mm
4	Qty. (4)	Hex Nut, 1/2	14	Qty. (2)	Hex Nut, M8
5	Qty. (6)	5/8 Conical Toothed Washer	15	Qty. (2)	Conical Washer, 3/8
6	Qty. (1)	Cable Tie (not shown)	16	Qty. (2)	Spacer, 3/8 X 1.50 X 2.00
7	Qty. (6)	Hex Nut, 5/8	17	Qty. (2)	Locknut, 7/16-14
8	Qty. (2)	Carriage Bolt, 5/8-11 X 2.50 GR5	18	Qty. (2)	Hex Bolt, 7/16-14 X 1.50
9	Qty. (2)	Block, 5/8 X 1.50 X 2.00	19	Qty. (4)	Shims, 1/4 X 2.00 X 1.00
10	Qty. (1)	Hex Bolt, 1/4-20 X 1.25			

# Installation Instructions

## GOOSENECK MOUNTING KIT

Part Numbers:

4448

### Ford F-250/F-350 Super Duty

Will not fit Cab-on-Chassis vehicles

#### NOTES:

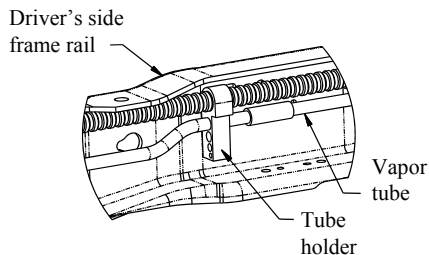
- This rail kit can be used with a 6300, 8339, 83391, 83399 head only.
- Always make sure the ball is fully locked before towing.
- Keep the ball and ball pocket well lubricated.
- Periodically re-torque all the hitch fasteners.
- Check ball, hitch coupler, safety chains and other connections for proper operation every time you tow.

#### Warning:

- ❖ The tow vehicle manufacturers recommended towing capacities should UNDER NO CIRCUMSTANCES be exceeded.
- ❖ Check for adequate clearance between the gooseneck trailer and the rear of the cab and the rear of the truck box before installing hitch.
- ❖ All trucks have fuel lines, brake lines and electrical wiring located along the vehicle frame where the rail kit installs. Carefully examine the location of fuel lines, brake lines and electrical wires before installation and be certain not to damage these when positioning the hitch components. Be careful when drilling holes, cutting sheet metal and tightening fasteners as to not limit the integrity of these systems.

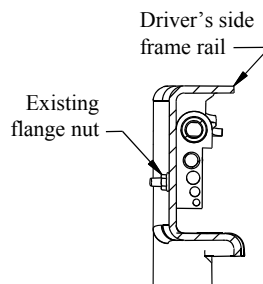
#### 6300 Remove-A-Ball and 8339, 83391, 83399 Fold Down Gooseneck Installation

1. Lower the vehicle exhaust.
2. **On Gas Engine Vehicles Only.** The vapor tube running along the inside of the driver's side frame rail must be relocated prior to installing the driver's side bracket (see Figure 2a). Remove the flange nut from the outside of the frame and keep for later use (see Figure 2b). Rotate the tubes up and out of the way. Install the L-bracket with 1/4" hardware, as shown in Figure 2c. Tighten the L-bracket to the frame, but leave the tube holder loose to aid bracket installation. The tube holder will be tightened onto the L-bracket in Step 18.

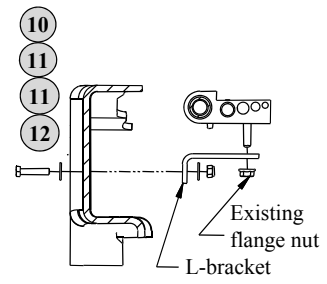


**Figure 2a**

Inside of frame rail

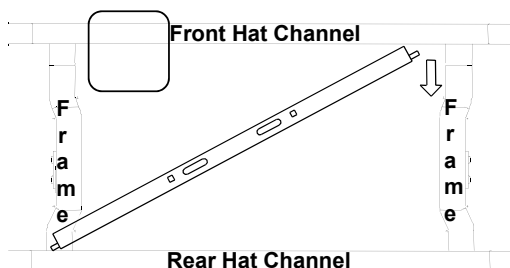


**Figure 2b**

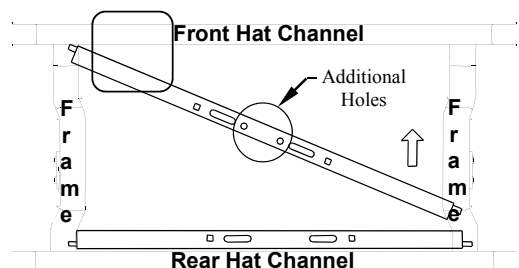


**Figure 2c**

3. From underneath the vehicle, install the **rearward** hitch cross member by placing one end above the vehicle frame and maneuvering the notched section of the opposite end above the vehicle frame. The forward cross member has two additional holes (see Figure 3). Temporarily position the rearward hitch cross member against the rear hat channel of the vehicle.
4. From underneath the vehicle install the **forward** hitch cross member by placing the driver's side notched end above the vehicle frame and maneuvering the opposite notched end above the exhaust and above the vehicle frame.



**Rear Cross Member Installation**



**Forward Cross Member Installation**

**Figure 3**

# Installation Instructions

## GOOSENECK MOUNTING KIT

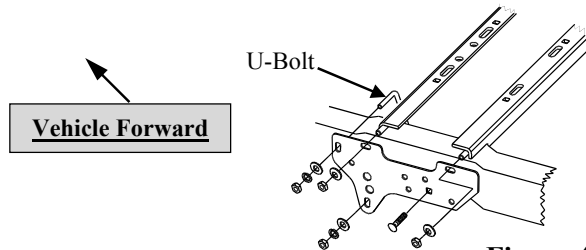
Part Numbers:

**4448**

### Ford F-250/F-350 Super Duty

Will not fit Cab-on-Chassis vehicles

5. Loosely install the driver's side and passenger's side hitch side brackets by attaching the 5/8" hardware to the threaded studs. Install the 5/8 X 2.50 carriage bolts through the hitch side brackets, 5/8" blocks and the large slots in the vehicle frame rails. Loosely, install the 5/8 Conical Toothed Washers and 5/8 hex nuts to the carriage bolts (see Figure 1).
6. Use the supplied U-Bolt for the forward attachment of the bracket to the frame (see Figure 4). Position U-Bolt from the inside of the vehicle frame pointing towards the hitch side bracket. On the passenger's side of the vehicle, the U-Bolt must be positioned to the vehicle forward side of the shock mount and installed on an angle through the mounting slots on the hitch side bracket.



**Figure 4**

7. Torque the 5/8"-11 GR5 fasteners connecting the forward cross member to the brackets to 150 ft.-lb. (203 N-m). Torque the 1/2"-13 U-Bolt fasteners to 75 ft.-lb (102 N-m). Torque the 5/8" nuts to the 5/8 X 2.50 carriage bolts to 150 ft.-lb. (203 N-m). The rearward cross member should be left loose until step 17.

**8a. For 6300 & 8339** use the **outer** edges of the long slots in the forward cross member as a template to drill 5/8" diameter holes through the truck bed as shown in Figure 5a. Not all holes can be drilled from under the vehicle, but will be done later from inside the bed.

**8b. For 83391 & 83399** use the **inner** edges of the long slots in the forward cross member as a template to drill 5/8" diameter holes through the truck bed as shown in Figure 5b. Not all holes can be drilled from under the vehicle, but will be done later from inside the bed.

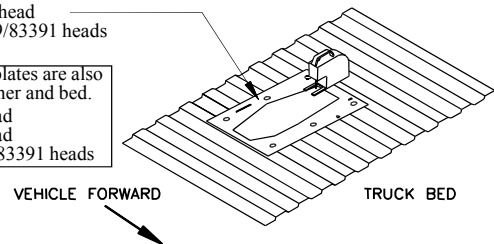
9. Align the holes on the template (provided with the gooseneck hitch) with the holes previously drilled through the bed. Be sure that the template is properly oriented toward the front of the vehicle. Center punch the holes that will be used to cut the opening in the bed. If the vehicle is equipped with a bed liner, a section of the bed liner must be cut away so that the gooseneck hitch can contact the bed corrugations.

10. Drill 1/4" pilot holes (size will depend on width of blade in saber saw). Cut out the truck bed, file the edges as needed.

11. Install the hitch into the opening.

Template p/n 5978 for use with 6300 head  
 Template p/n 114234 for use with 8339 head  
 Template p/n 114523 for use with 83399/83391 heads

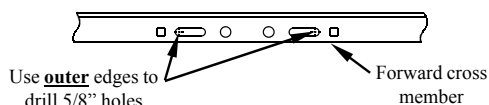
Durable and reusable stainless steel templates are also available. A time saver for cutting bed liner and bed.  
 Template p/n 6467 for use with 6300 head  
 Template p/n 6425 for use with 8339 head  
 Template p/n 58384 for use with 83399/83391 heads



**⚠ WARNING** The fuel tank and/or other vehicle components are located below some of the holes. A wood or metal shield must be placed between the frame and the fuel tank to prevent puncturing the fuel tank when the drill breaks through the bed.

12. Use the hitch as a guide to drill the 5/8" diameter holes for the rearward cross member. Also, drill 5/8" diameter U-Bolt holes if installing a 6300 or 8339 gooseneck hitch.
13. Before installing the 5/8" carriage bolts through the hitch, the U-Block shims (Part Number 5994) must be placed between the hitch and the bed and between the cross members and the bottom of the bed. These shims are necessary to prevent the bed corrugations from collapsing when the bolts are tightened.
14. Align the rearward cross member with the 5/8 diameter drilled holes.

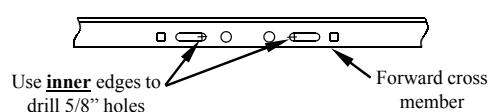
#### 6300/8339 Hole Locations



**Figure 5a**

Rearward cross member

#### 83399/83391 Hole Locations



**Figure 5b**

Rearward cross member

# Installation Instructions

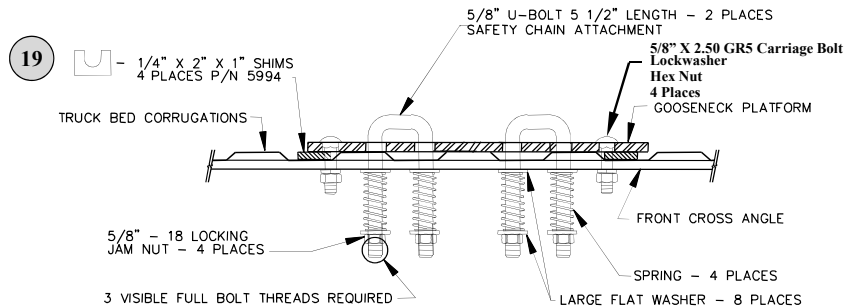
## GOOSENECK MOUNTING KIT

Part Numbers:

**4448**

### Ford F-250/F-350 Super Duty

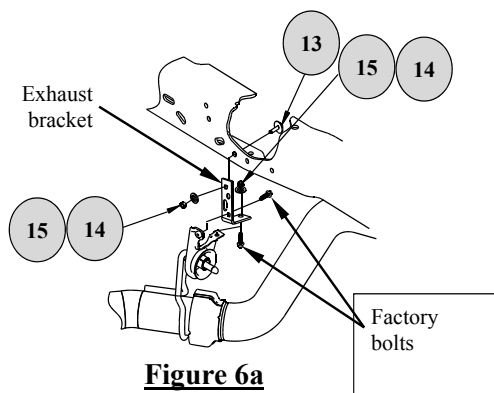
Will not fit Cab-on-Chassis vehicles



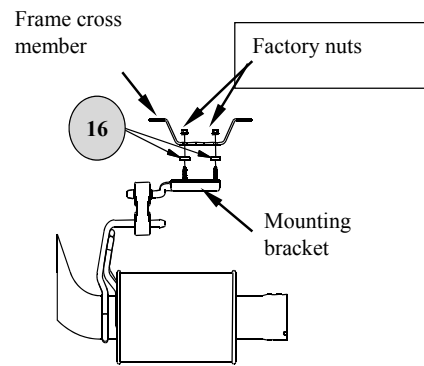
15. Install the 5/8" X 2.50 GR5 carriage bolts through the hitch, shims and cross members. Secure with lock washers and nuts. Torque nuts to 150 Lb.-Ft.
16. **For 6300 and 8339 Installations:** Install the (2) U-Bolts through the hitch. From under the vehicle install large flat washer over the U-Bolt followed by a spring, another large flat washer and secure with a thin 5/8" jam nut. Repeat for other legs of the U-Bolts. The 5/8" jam nuts are tightened until 3 threads are visible past the bottom of the jam nut.
17. Torque the 5/8-11 GR5 fasteners connecting the rearward cross member to the brackets to 150 ft.-lb. (203 N-m).
18. **On gas vehicles only:** Use the factory flange nut that was removed in step 2 to tighten the tube holder onto the L-bracket and shown in figure 2c.
19. Reinstall exhaust as shown below.

**Exhaust installation:**

20. If there is less than 1/2" clearance between the exhaust pipe and the cross members, the exhaust bracket supplied with the 4448 mounting kit must be used (See figure 6a and 6b). For the rear attachment (Figure 6a), fasten the supplied bracket extension to the factory bracket with the factory hardware. Reattach the exhaust bracket forward of the axle to the frame cross member with 3/8" spacers sandwiched between the bracket and cross member.



**Figure 6a**  
Rear Attachment



**Figure 6b**  
Center Attachment