

# RC-01

## Installation Instructions

1. Locate brake line union behind cab inside left frame rail.
2. Remove union and replace with RC-01 inline residual check valve, making certain that the arrow on the valve is pointing toward the rear wheels. Drill  $\frac{1}{4}$ " hole and attach mounting bracket to frame rail.

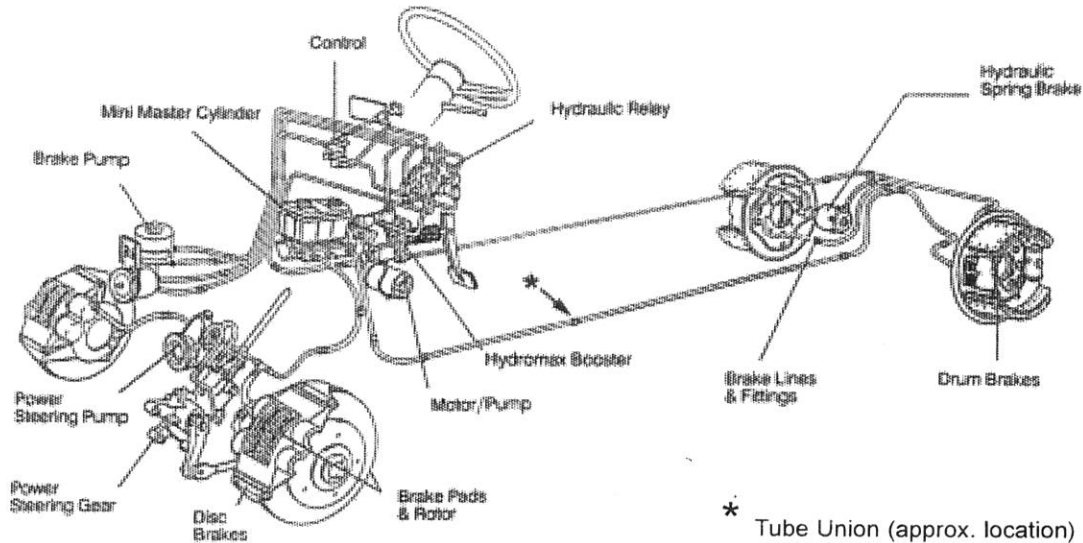

### IMPORTANT NOTE:

Arrow on check valve must point toward the rear wheels!

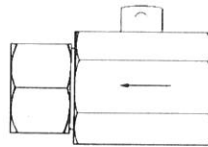

3. Make several stationary applications and bleed the rear brakes.

### Installation Tip:

When installing this check valve it is possible to avoid bleeding the rear brakes if the following procedure is properly performed.

Insert the forward most tube and tighten the tube nut.

Insert rear tube and start tube nut, but do not tighten.

Have someone slowly depress the brake pedal and tighten the tube nut after fluid begins to leak around the threads.

Check the fluid level in the master cylinder and pedal for proper "feel". Road test the vehicle.