

KIT MASTERS

FAN CLUTCH EXPERTS

7500HP / 9500HP Kit Assembly Instructions

DISASSEMBLY

1. Remove Torx screws from air chamber - using T30 bit
2. Remove air chamber from fan clutch
3. Holding air chamber upside-down, remove O-Ring and face seal
4. Remove friction plate
5. Remove large O-Ring from friction plate
6. While fan clutch is in a vise, remove locknut using 1 1/2" socket
7. Remove hub assembly
8. Using a snap ring pliers, remove the snap ring from the center of the shaft
9. Remove old air cartridge
10. Remove journal spacer from journal bracket
11. Remove sheave from journal bracket
12. Press out the two old bearings from the sheave – save any spacers between the bearings
13. Remove torx screws and friction facing from sheave – using T25 bit

INSTALLATION

1. Clean all pieces with a wire brush and cleaning solution
2. Press in one of the new bearings into the sheave, pulley (if there were spacers between the bearings in the pulley, you must reuse both of them), then press in the second new bearing.
3. Install sheave over the journal bracket
4. Use supplemental instructions to determine correct journal spacer
5. Place journal spacer over journal bracket. Place Lip Side Up
6. Install new friction facing and Torx screws, torque to 35 inch pounds – using T25 bit
7. Install assembled hub over shaft
8. Torque locknut to 150 Lbs.-ft. – using 1 1/2" socket
9. Apply O-ring lube to large O-ring and install on friction plate
10. Place friction plate over hub assembly
11. Apply O-ring lube to small O-ring and install on air chamber
12. Apply O-ring lube on air cartridge and install new air cartridge in journal bracket
13. Install new snap ring over air cartridge
14. Install new face seal into air chamber
15. Place air chamber over friction plate
16. Install and tighten air chamber Torx screws to 180-inch pounds torque – using T30 bit
17. Do NOT remove white Teflon Fuse

Patent(s) Pending. See www.kit-masters.com for updated list of applicable issued and pending patents.

Video demonstration available at www.kit-masters.com

Instrucciones en Español en www.kit-masters.com

For installation assistance, contact Kit Masters at (800)-810-9110

Pieces included in kit

HP series only

Reusable pieces

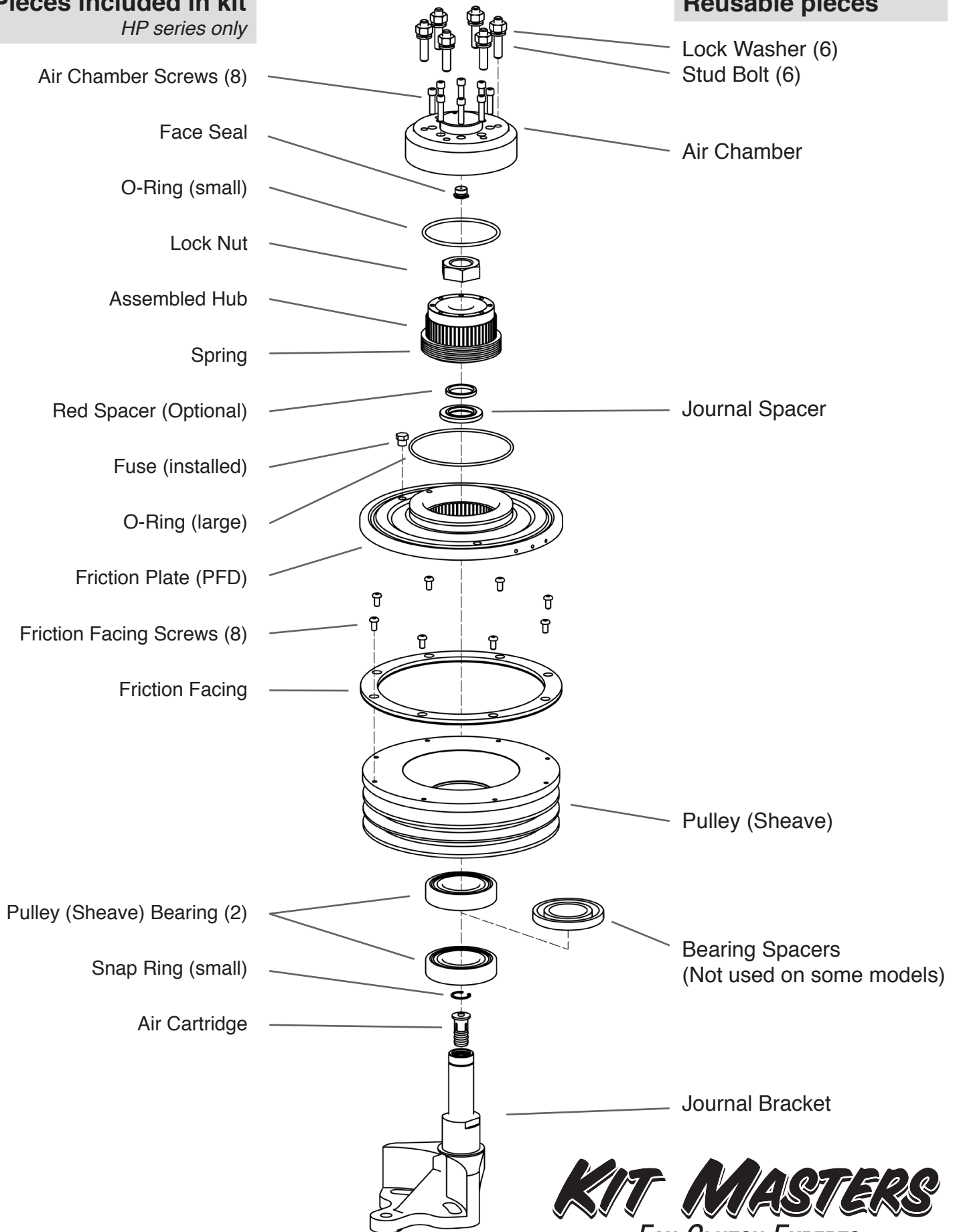

KIT MASTERS
FAN CLUTCH EXPERTS

www.kitmasters.com

Fan Clutch Overhaul Instructions Supplement (HP Kits) JOURNAL SPACERS

STEP 1

Determine the style of hub your are replacing:

Standard Hub

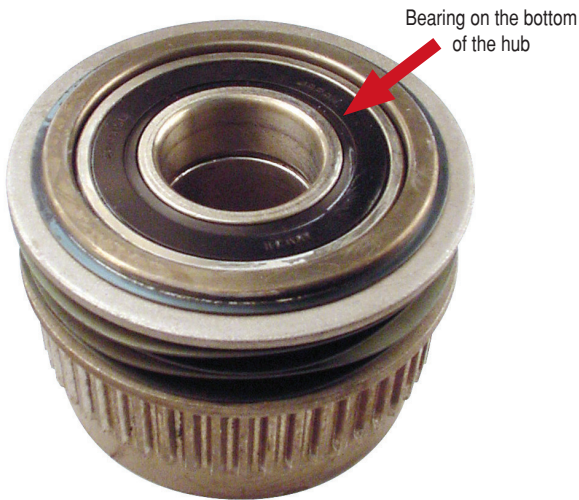

If you have this style hub, reuse your old journal spacer and discard these instructions and parts

Your old journal spacer should look like this:

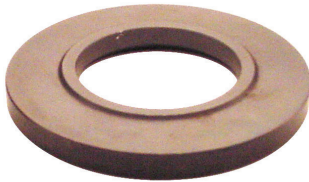

Non-Standard Hub - One bearing system

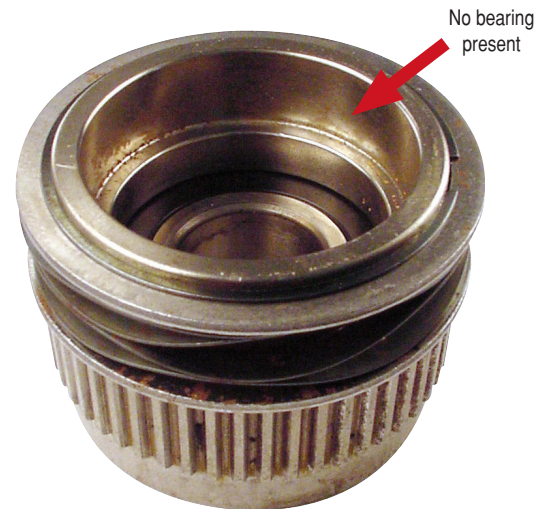

If you have this style hub, you will be upgrading to a new, two bearing hub, but will need to use the journal spacer and possibly the red spacer included with these instructions

Pictured below is the non-standard journal spacer that you would have with this style hub. You will need to take a measurement on this spacer (see other side), but then it can be discarded.



STEP 2

Now that you have determined that you have the non-standard hub, you will be upgrading to a two bearing hub system and need to use the journal spacer provided. To determine if you need the red spacer on top of the journal spacer, compare your spacer to the dimensions below.

Lay your non-standard journal spacer between the lines below. **Lay it on its side.**

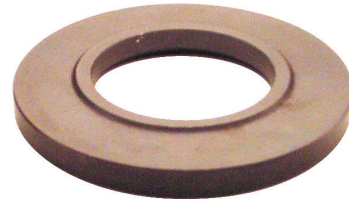
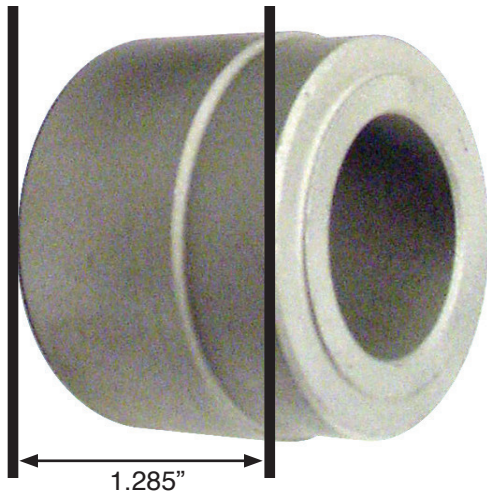

Standard Journal Spacer

Install
with the
LIP UP

If your non-standard journal spacer fits **INSIDE** the lines above (1.285") — it should not touch either line — then use the standard journal spacer provided (discard the red spacer). If it doesn't fit, go to step 3.

STEP 3

If your non-standard journal spacer did not fit **INSIDE** the first set of lines above (1.285"), but fits **INSIDE** the 1.350" lines below, then use the standard journal spacer and place the red spacer over the top of it. Your new hub will slide over the journal bracket and on top of the red spacer.

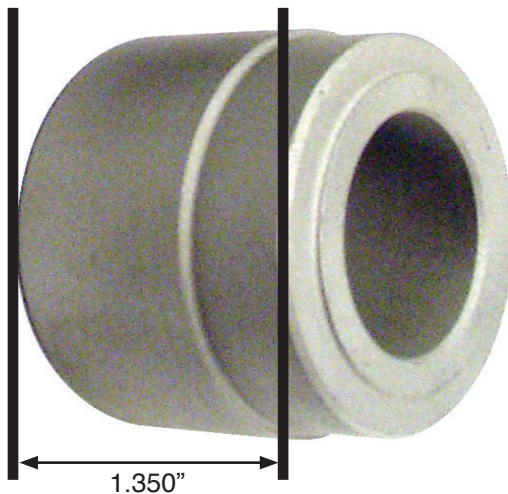

Red Spacer



Install
with the
LIP UP

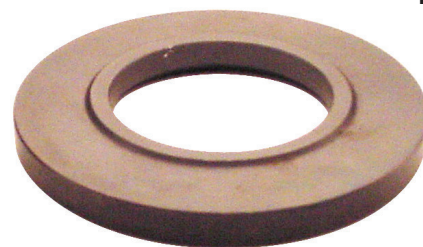

Standard Journal Spacer