

# Installation Instructions

## 6451050 – Push/Pull Style Lift Axle Control Assembly

## 6451051 – Toggle Style Lift Axle Control Assembly

The lift axle control assemblies are designed specifically for vehicle based air suspension and lift axle applications.

### WARNING

**ALWAYS WEAR PROPER EYE PROTECTION AND OTHER PERSONAL SAFETY EQUIPMENT WHEN PERFORMING ANY SERVICE ON YOUR VEHICLE AND/OR ANY OF ITS SYSTEMS.**

### WARNING

**DISCONNECT THE BATTERY AND RELEASE STORED AIR PRESSURE IN ALL SYSTEM COMPONENTS BEFORE PERFORMING ANY SERVICE ON THE SYSTEM.**

### WARNING

**THE SYSTEM AIR MUST BE MOISTURE FREE IF TEMPERATURES ARE BELOW FREEZING TO ENSURE RELIABLE PERFORMANCE.**

### Installation and Operation:

- Using 1/4" DOT approved tubing, plumb the air supply into the Supply fitting as shown in FIGURE A.
- Using 1/4" DOT approved tubing, plumb the output air from the Air Outlet fitting as shown in FIGURE A.

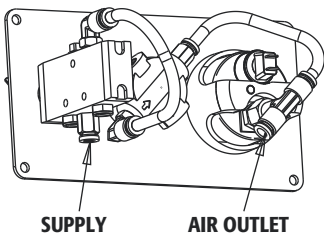
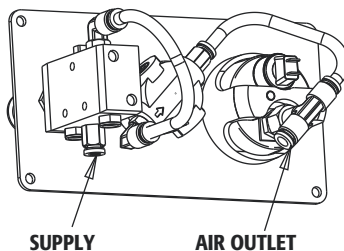

Fig. A



**6451050 – Push/Pull Style Lift Axle Control Assembly**



**6451051 – Toggle Style Lift Axle Control Assembly**

### WARNING

**AFTER ANY WORK IS COMPLETED, THE AIR AND ELECTRICAL SUPPLIES CAN BE RECONNECTED AND LEAK TESTING SHOULD BE PERFORMED ON THE PRODUCT. DO NOT USE THE PRODUCT IF ANY AUDIBLE LEAK IS DETECTED OR IF IT DOES NOT FUNCTION PROPERLY.**

- The operator will control the outlet pressure, displayed by the illuminated gauge, using the regulator. The pressure is increased by turning the regulator clockwise and is reduced by turning the regulator counterclockwise.
- To raise the lift axle, the operator will either PULL the valve OUT or toggle the valve UP depending on which assembly they have.
- To lower the lift axle, the operator will either PUSH the valve IN or toggle the valve DOWN depending on which assembly they have.

### WARNING

**CONFIRM THE AREA SURROUNDING THE LIFT AXLE IS CLEAR BEFORE OPERATION. MAKE SURE THE TRUCK IS IN PARK WITH THE PARKING BRAKE ENGAGED BEFORE RAISING OR LOWERING THE LIFT AXLE.**

—continued on back

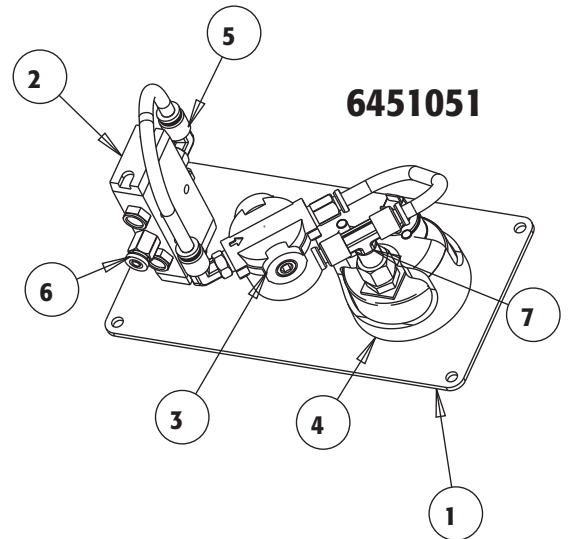
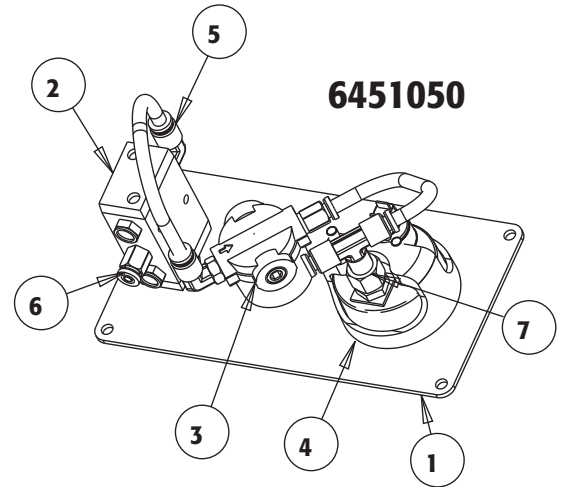
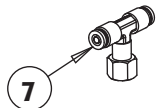
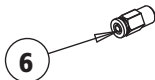
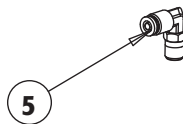
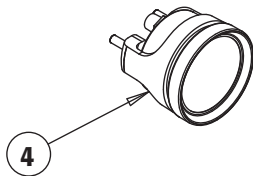
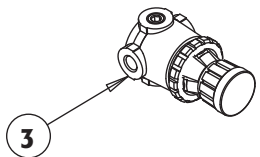
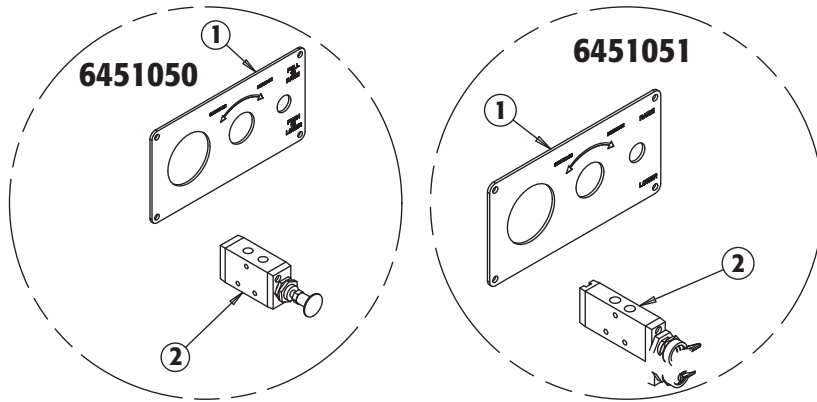

## Bill of Materials

ITEM	PART NO.	QTY.	DESCRIPTION
1	3023190	1	Plate, Lift Axle, Push/Pull
	3023191	1	Plate, Lift Axle, Toggle
2	BAV010	1	Valve, Air, Push/Pull
	6451030	1	Valve, Air, Toggle
3	6451025	1	Regulator, Pressure, (2) 1/8" Work Ports
4	6451035	1	Gauge, Pressure, 2" Dial, 0-160 PSI, 1/8"
5	BE90M25P125S	2	Fitting, Male Swivel, Elbow, Dot, Push-In, 1/4" X 1/8" Pipe Thd.
6	BC00M25P125	2	Fitting, Connector, Male, Dot, Push-In, 1/4" X 1/8" Pipe Thd.
7	BBT0F25P125S	1	Fitting, Female Branch Tee, Swivel, Dot, Push-In, 1/4" X 1/8" Pipe Thd
8	H3179X2	1	Plug, Sq. Head 1/8
9	BAV01502	2	Air Valve Breather 1/8" NPT

## WARRANTY

Buyers Products Co. warrants all truck/trailer hardware manufactured or distributed by it, to be free from defects in material and workmanship for a period of one year from date of shipment. Parts must be properly installed and used under normal conditions. Any product which has been altered, including modification, misuse, accident or lack of maintenance will not be considered under warranty. Normal wear is excluded. The sole responsibility of Buyers Products Co. under this warranty is limited to repairing or replacing any part or parts which are returned, prepaid, and are found to be defective by Buyers Products Co. Authorization from Buyers Products Co. must be obtained before returning any part. No charges for transportation or labor performed on Buyers' products will be allowed under this warranty.