

Owner's Manual

EH-3050 Series E-Hitch™

Installation, Operation and
Maintenance Procedures

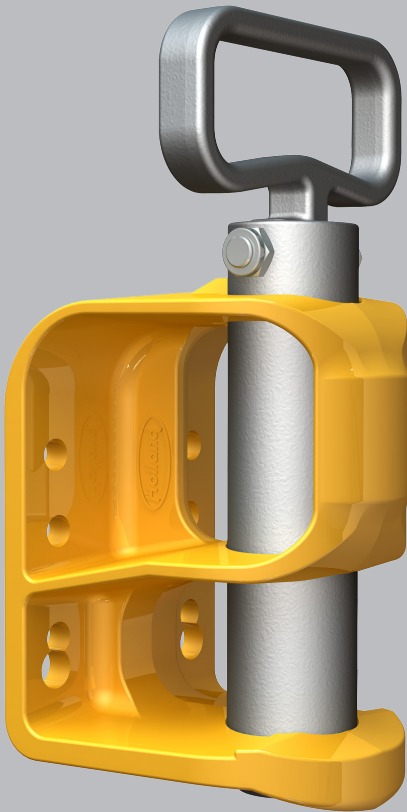

Patents (US 8,336,902 B2) (US 8,540,270 B2)
Other Patents Pending

Contents	Page
Introduction.....	2
Towing Applications.....	2
Notes, Cautions, and Warnings.....	2
Section 1 – General Safety Instructions.....	3
Section 2 – Dimensional Layout and Parts Identification.....	3
Section 3 – Design and Performance Specifications.....	4

Contents	Page
Section 4 – Model Identification.....	4
Section 5 – Installation Instructions.....	5
Section 6 – Operating Instructions.....	7
Section 7 – Converting Handle.....	8
Section 8 – Maintenance Procedures.....	9
Section 9 – Repair Kits and Ordering Information.....	11

Introduction

This manual provides the information necessary for the proper operation and maintenance of the SAF-HOLLAND® EH-3050 E-Hitch.

Towing Applications

Designed for airport ground support and industrial material handling applications. This product is NOT approved by SAF-HOLLAND for over-the-road use.

NOTE: SAF-HOLLAND reserves the right, without giving prior notice, to change specifications and dimensions as designs are altered or improved.

IMPORTANT: Keep this manual in a safe location for future reference.

Notes, Cautions, and Warnings

Read and understand all of the procedures presented in this manual before starting any work on the E-Hitch.

Proper tools MUST be used to perform the maintenance and repair procedures described in this manual.

NOTE: In the United States, workshop safety requirements are defined by federal and/or state Occupational Safety and Health Act. Equivalent laws could exist in other countries. This manual is written based on the assumption that OSHA or other applicable employee safety regulations are followed by the location where work is performed.

This manual contains the terms "NOTE", "IMPORTANT", "CAUTION", and "WARNING" followed by important product information. These terms are defined as follows:

NOTE: Includes additional information to enable accurate and easy performance of procedures.

IMPORTANT: Includes additional information that if NOT followed could lead to hindered product performance.

CAUTION Used without the safety alert symbol, indicates a potentially hazardous situation which, if not avoided, could result in property damage.

CAUTION Indicates a potentially hazardous situation which, if not avoided, could result in minor or moderate injury.

WARNING Indicates a potentially hazardous situation which, if not avoided, could result in death or serious injury.

1. General Safety Instructions

Before beginning installation, read and observe all Warning and Caution hazard alert messages in this publication. The alerts provide information that can help prevent serious personal injury, damage to components, or both.

The E-Hitch installation and maintenance **MUST** be performed by a trained technician using proper tools and safe procedures.

We highly recommend the use of only SAF-HOLLAND Original Parts.

A list of SAF-HOLLAND technical support locations to supply SAF-HOLLAND Original Parts can be found at www.safholland.us or contact SAF-HOLLAND Customer Service at 888-396-6501.

Updates to this manual will be published as necessary online at www.safholland.us.

2. Dimensional Layout/Parts Identification

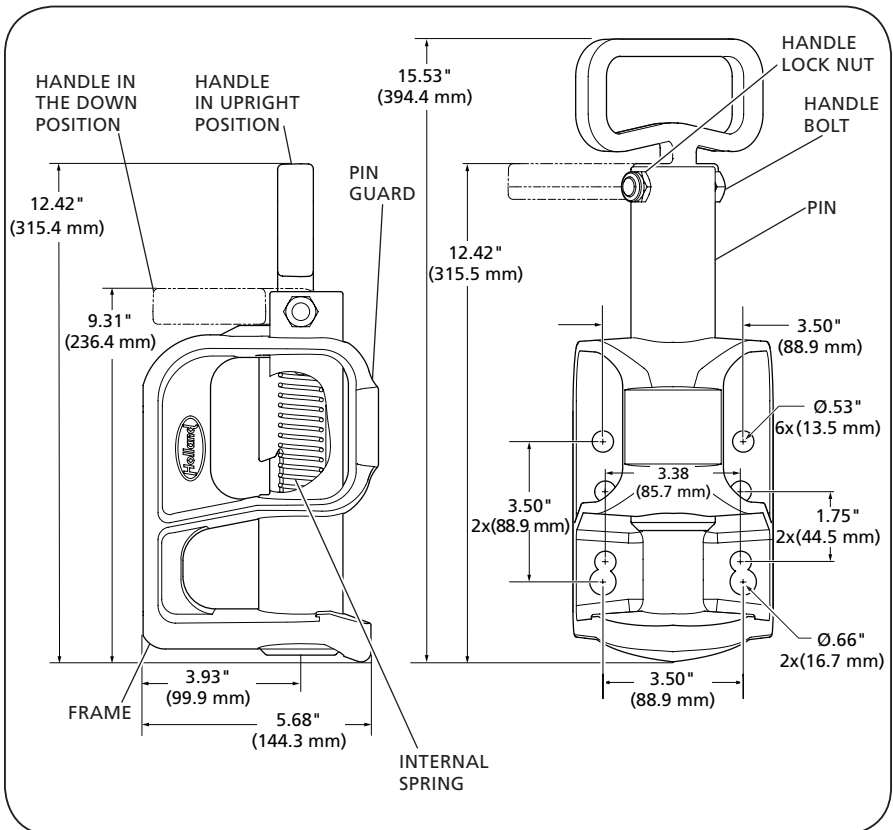

3. Design and Performance Specifications

Hitch rating 1/2" bolts

Maximum D.B.P.30,000 lbs. (13,608 kg)
 Maximum Vertical 500 lbs. (227 kg)
 Hitch Weight 22 lbs. (10 kg)

Hitch rating 5/8" bolts

Maximum D.B.P. 50,000 lbs. (22,680 kg)
 Maximum Vertical 500 lbs. (227 kg)
 Hitch Weight 22 lbs. (10 kg)

Application Drawbar eye

Minimum Inside Dia. 2-1/4" (57 mm)
 Maximum Inside Dia. 3" (76 mm)
 Max. Cross Section Dia. ... 1-3/4" (45 mm)

4. Model Identification

All EH-3050 E-Hitches have an internal spring and a "Pin Guard" surrounding the top half of the pin, refer to **Table 1**.

The rating and operation label is located on the top of the product behind the pin (**Figure 1**).

Figure 1

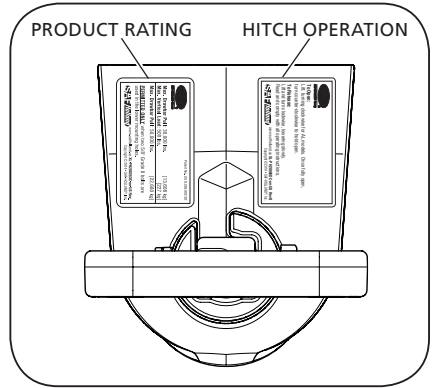

Table 1

E- HITCH MODEL		PIN	
EH-3050	(Blank)	Non-Lock (Standard)	
	AL	Auto-Lock (Optional)	

EH-3050	X	X	-	X	X
---------	---	---	---	---	---

FRAME COLOR	
13	Safety Yellow (Standard)
14	White (Standard)
17	Red (Optional)

Examples:

EH-3050-14 includes standard non-lock pin and standard white color.

EH-3050-AL-13 includes optional auto-lock pin and standard safety yellow color.

5. Installation Instructions

The SAF-HOLLAND EH-3050 E-Hitch can be mounted three (3) different ways with two (2) load ratings. **Figures 2 through 4** show the hole pattern configurations that can be used with this product.

NOTE: This product has NOT been tested nor is it rated for use in a weld on application. Welding on the product will change the mechanical state of the material and cause an unsafe condition.

⚠ WARNING Failure to remove a welded EH-3050 from service will result in unexpected E-Hitch failure which, if not avoided, could result in death or serious injury.

NOTE: Mount the hitch to a secure structure with sufficient strength to support the load rating.

Rating 30,000 lbs. (13,608kg) (Figure 2)
Use four (4) 1/2" Grade 8 bolts with supplied hardened thick flat washers. Torque 1/2" bolts (clean and dry) to 100 ft.-lbs. (135 N•m) minimum. Nuts used MUST be ASTM grade "C" or better.

This hole pattern will match the following products:

- HOLLAND®: EH-20RPXX Series E-Hitches

Rating 30,000 lbs. (13,608kg) (Figure 3)
Use four (4) 1/2" Grade 8 bolts with supplied hardened thick flat washers. Torque 1/2" bolts (clean and dry) to 100 ft.-lbs. (135 N•m) minimum. Nuts used MUST be ASTM grade "C" or better.

This hole pattern will match the following products:

- HOLLAND: PH-30, PH-30RP Series
PH-10PR Series
PH-T-60-AOL-8
PH-T-60-AL
BH-200RN Series

Figure 2

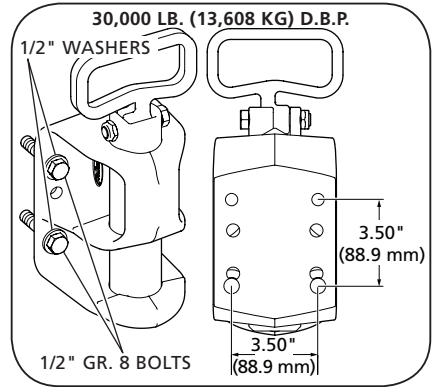
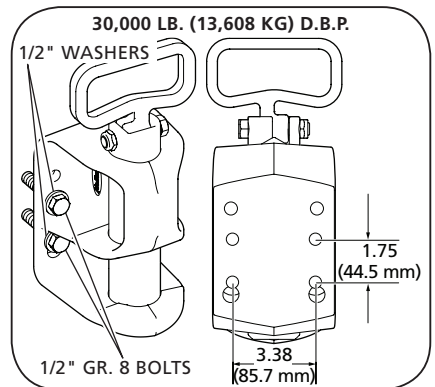

Figure 3



Rating 50,000 lbs. (22,680kg) (Figure 4)

Use two (2) 5/8" Grade 8 bolts with supplied hardened clipped washers (clipped edge facing down) in lower holes. Torque 5/8" bolts (clean and dry) to 180 ft.-lbs. (245 N•m) minimum. Use two (2) 1/2" Grade 8 bolts with supplied hardened flat washers in upper holes. Torque 1/2" bolts (clean and dry) to 100 ft.-lbs. (135 N•m) minimum. Nuts used MUST be ASTM grade "C" or better.

This hole pattern will match the following products:

- HOLLAND: EH-40RP Series E-Hitches

⚠ WARNING Failure to use supplied washers or proper bolts when mounting could result in unexpected E-Hitch failure, which if not avoided could result in death or serious injury.

Figure 4

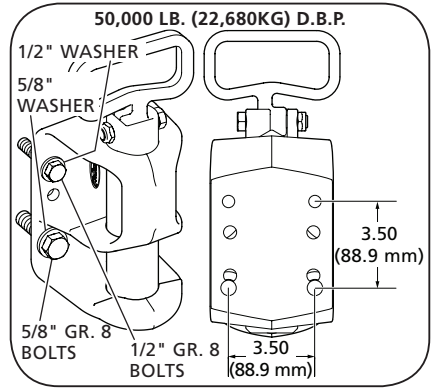

6. Operating Instructions

6.1 Opening Straight Pull Hitch Pin (Figure 5)

1. Grasp the handle and lift until the pin contacts the spring catch.
2. Rotate the pin counter clockwise until the pin lock rests on top of the hitch body.

6.2 Opening Auto Lock Hitch Pin (Figure 6)

1. Grasp the handle and lift while turning clockwise. As the handle rises it will turn about 45° in the auto lock notch allowing the pin to be pulled until it contacts the spring catch.
2. Rotate the pin counter clockwise until the pin lock rests on top of the hitch body.

6.3 Closing E-Hitch (Figure 7)

1. Position the drawbar eye in the bottom opening of the E-Hitch. Align the eye of the drawbar under the pin.
2. To close, grasp the handle, lift slightly and rotate the pin clockwise until the pin contacts the spring catch.
3. Lower the pin through the drawbar eye, check that the pin is fully seated.

NOTE: Be sure the drawbar size is compatible with the coupling device on the tow vehicle. Refer to Section 3.

NOTE: Pinch points exist where the pin slides through the E-Hitch frame and where the handle attaches to pin.

CAUTION

Failure to keep fingers away from the pin and E-Hitch frame while operating could result in pinched fingers, which if not avoided, could result in minor or moderate injury.

Figure 5

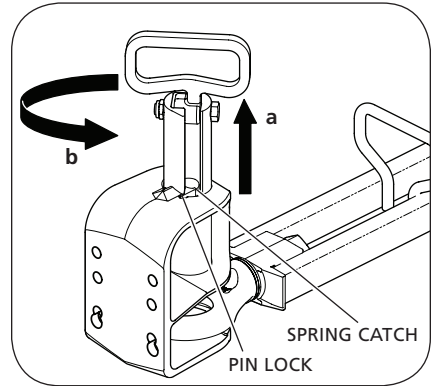

Figure 6

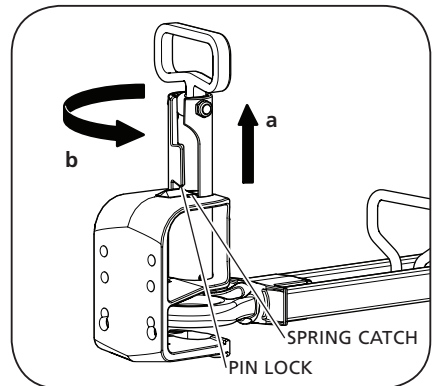
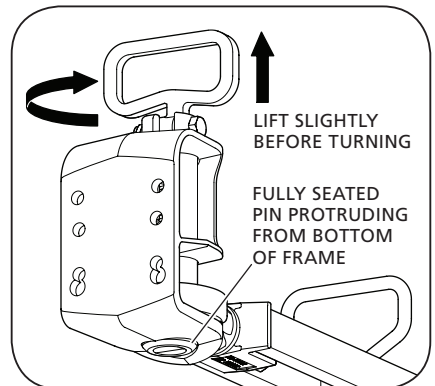

Figure 7



7. Converting Handle

The E-Hitch is packaged with the handle in the drop style position. The following instructions are for converting the hitch handle from a drop style to a fixed upright style or vice-versa.

1. If the E-Hitch is NOT mounted securely to a vehicle the hitch frame should be gripped in a vise of adequate size to secure the hitch while converting.

CAUTION Failure to support the hitch pin while changing the handle could result in ejection of the hitch pin, which if not avoided, could result in minor or moderate injury.

2. Pull up on the handle to retract the hitch pin.
3. Place a block of wood between the hitch pin and the E-Hitch frame and release the handle.
4. Remove the lock nut and bolt, pull out the handle and rotate handle 180° (**Figure 8**).
5. Replace the lock nut and bolt. Tighten the lock nut to contact with the pin plus 1/2 turn. The handle will now fold down towards the rear of the hitch.
6. Pull up on the handle and remove the block of wood placed in Step 3.
7. Check for proper operation before continued use of the E-Hitch.

Figure 8

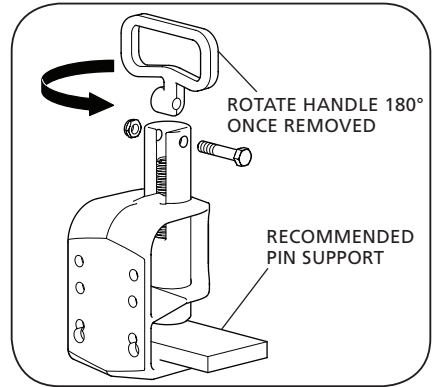

8. Maintenance Procedures

Perform the following every three months for proper performance.

- Clean and check for proper operation.
- Inspect for worn, damaged, or missing parts.
- Inspect mounting and verify it is secure.
- Correct and replace parts as required using only genuine SAF-HOLLAND replacement parts (Refer to Section 9 for spare parts).
- Using a light oil, lubricate the handle pivot and internal spring (**Figure 9**).
- Using a (caliper or micrometer) inspect the towbar eye contact area of the pin for wear and damage. If wear exceeds 0.13" (3 mm) from the original surface profile replace the pin.
- Inspect the pin contact area for wear and damage. If wear exceeds .13" (3 mm) (3 mm) from the original surface profile replace the pin (**Figure 10**).
- Inspect the pull force on the pin for proper spring tension. This can be done by use of a hand held force gage. Attach the gage to the handle and pull the pin up until it is approximately 1" (25 mm) above the top of the bottom flange (**Figure 11**).

Figure 9

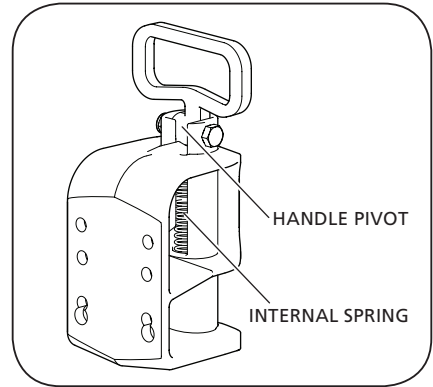

Figure 10

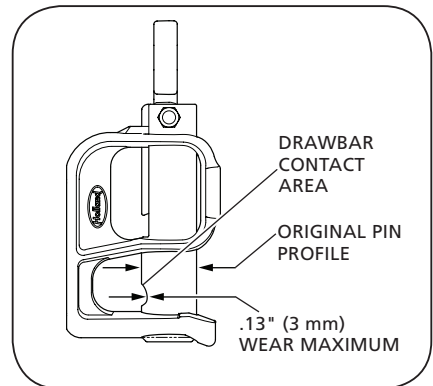
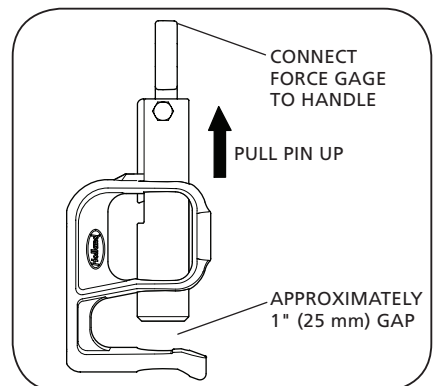
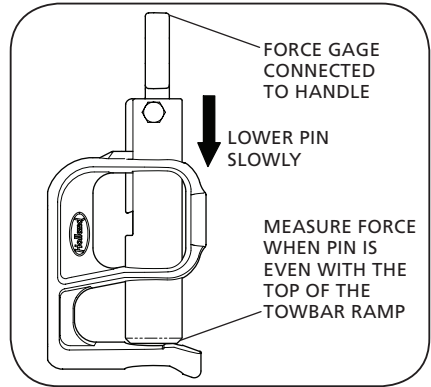

Figure 11



- Lower the pin until the bottom of the pin is even with the top of the towbar ramp (**Figure 12**). This is done to insure there is nothing snagging on the pin to give a false reading. When the pin bottom is level with the top of the towbar ramp the force gage should read according to **Table 2**.

Figure 12



E-HITCH PIN TYPE	NO LESS THAN (POUNDS)	NO LESS THAN (NEWTONS)
Non-lock Pin	20	89
Auto-lock Pin	10	44

Regardless of the reading on the force gage, if the spring is broken it **MUST** be replaced. The replacement spring for the non-lock pin is part number XA-11423-G. The replacement kit for the auto-lock pin is part number RK-11789. Refer to section 9 for ordering information.

⚠️ WARNING

Failure to follow the above maintenance instructions could result in unintentional uncoupling during operation which, if not avoided, could result in death or serious injury.

9. Repair Kits and Ordering Information

Listed below are the repair kits offered for the E-Hitch (**Figure 13**).

To order please call, SAF-HOLLAND Customer Service at 1-888-396-6501.

Specify the kit numbers required along with the quantity needed.

NOTE: The E-Hitch frame is NOT a saleable item. In order to receive a frame a full assembly MUST be ordered.

RK KITS		
ITEM	REBUILD AND REPLACEMENT KITS	PART #
1	Handle, Lock Nut, Handle Bolt	RK-11440
2	Straight Pin, Spring, Lock Nut, Handle Bolt	RK-11439
3	Auto Lock Pin Assembly, Lock Nut, Handle Bolt	RK-11789
4	E-Hitch Frame NOT offered for sale	N/A

Figure 13

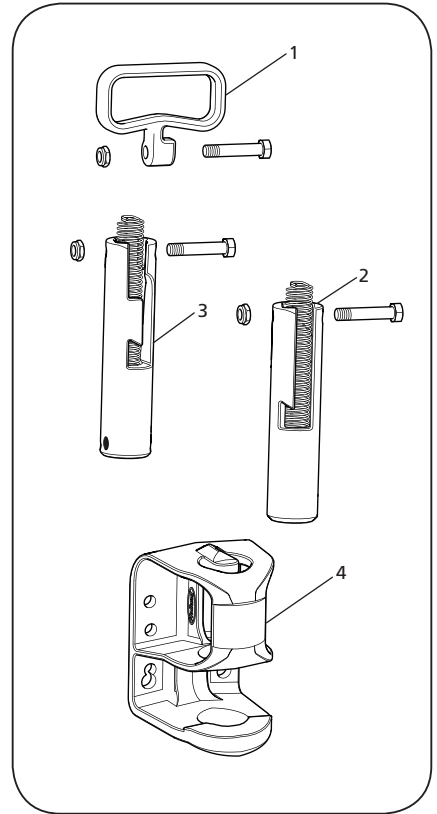



From fifth wheel rebuild kits to suspension bushing repair kits, SAF-HOLLAND Original Parts are the same quality components used in the original component assembly.

SAF-HOLLAND Original Parts are tested and designed to provide maximum performance and durability. Will-fits, look-a likes or, worse yet, counterfeit parts will only limit the performance potential and could possibly void SAF-HOLLAND's warranty. Always be sure to spec SAF-HOLLAND Original Parts when servicing your SAF-HOLLAND product.

SAF-HOLLAND USA • 888.396.6501 • Fax 800.356.3929
www.safholland.us

SAF-HOLLAND CANADA • 519.537.3494 • Fax 800.565.7753
WESTERN CANADA • 604.574.7491 • Fax 604.574.0244
www.safholland.ca

SAF-HOLLAND MEXICO • 52.55.5362.8743 • Fax 52.55.5362.8743
www.safholland.com.mx

info@safholland.com

SAF-HOLLAND INC.
1950 Industrial Blvd, Muskegon, MI 49442
www.safholland.com

