



Service Data

SD-05-1269

Bendix® ASA-5® Automatic Slack Adjuster

DESCRIPTION

The Bendix® ASA-5® automatic slack adjuster is designed for use on cam actuated drum brakes of the type in use on most highway vehicles. Like a manual slack adjuster, the ASA-5® slack adjuster multiplies and transforms the linear force of the air actuator into a rotational force or torque which is used to apply the foundation brake. Additionally, the ASA-5® slack adjuster automatically adjusts the clearance between the brake lining and drum to compensate for wear.

A variety of ASA-5® slack adjuster configurations are offered including both straight arm and 5/8" yoke offset models. The ASA-5® slack adjuster is offered in arm lengths of 5, 5-1/2 and 6 inches and worm gear splines to accommodate the standard 1-1/4" and 1-1/2" SAE 10C, 24, 28 and 37 tooth splines.

Either of two yoke designs (easy-on and quick connect) in combination with an external manual adjuster hex provides for convenient installation and maintenance of the ASA-5® slack adjuster. **Note: The manual adjuster hex is intended for use during installation. CAUTION: Automatic slack adjusters should not be adjusted manually to correct excessive pushrod stroke.**

OPERATION

GENERAL

The automatic adjustment provided by the Bendix® ASA-5® slack adjuster results in consistent brake lining to drum clearance and brake actuator stroke. The key to its operation is the ability to complete the brake adjustment during the early part of each brake application and to cease adjusting as resistance to brake cam rotation begins to build. This aspect of the adjuster mechanism's operation prevents over-adjustment caused by lining compression, actuator bracket deflection, drum and foundation brake component distortion, or brake component wear.

The ASA-5® slack adjuster incorporates a clutch-type adjuster mechanism that continuously adjusts in very small increments as lining and drum wear occurs. The adjustments made by the ASA-5® slack adjuster are, therefore, not in specific increments relative to actuator stroke.

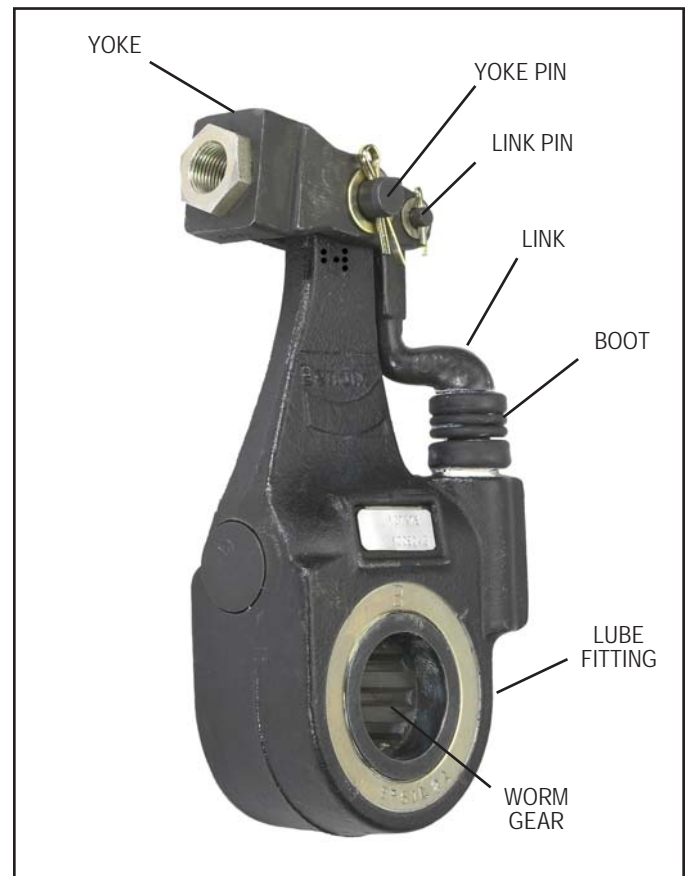

FIGURE 1 - ASA-5® AUTOMATIC SLACK ADJUSTER

BRAKE APPLICATION

When the brakes are applied, the linear travel of the brake actuator's push rod causes the ASA-5® slack adjuster to rotate the foundation brake camshaft which in turn begins to force the brake shoes into contact with the drum. When the ASA-5® slack adjuster rotates, the yoke assembly pivots on the yoke pin causing the link to be pulled upward.

The "teeth" on the link mesh with the adjuster mechanism pinion. As the link is pulled it travels first through its free play and then causes the pinion to rotate. Rotation of the pinion is transmitted through the clutch spring to the worm and shaft. Worm and shaft rotation results in worm gear rotation which in turn adjusts (or repositions) the brake camshaft.

When the foundation brake shoes contact the drum, the camshaft begins to resist rotation and friction between the worm gear and worm builds, preventing further rotation

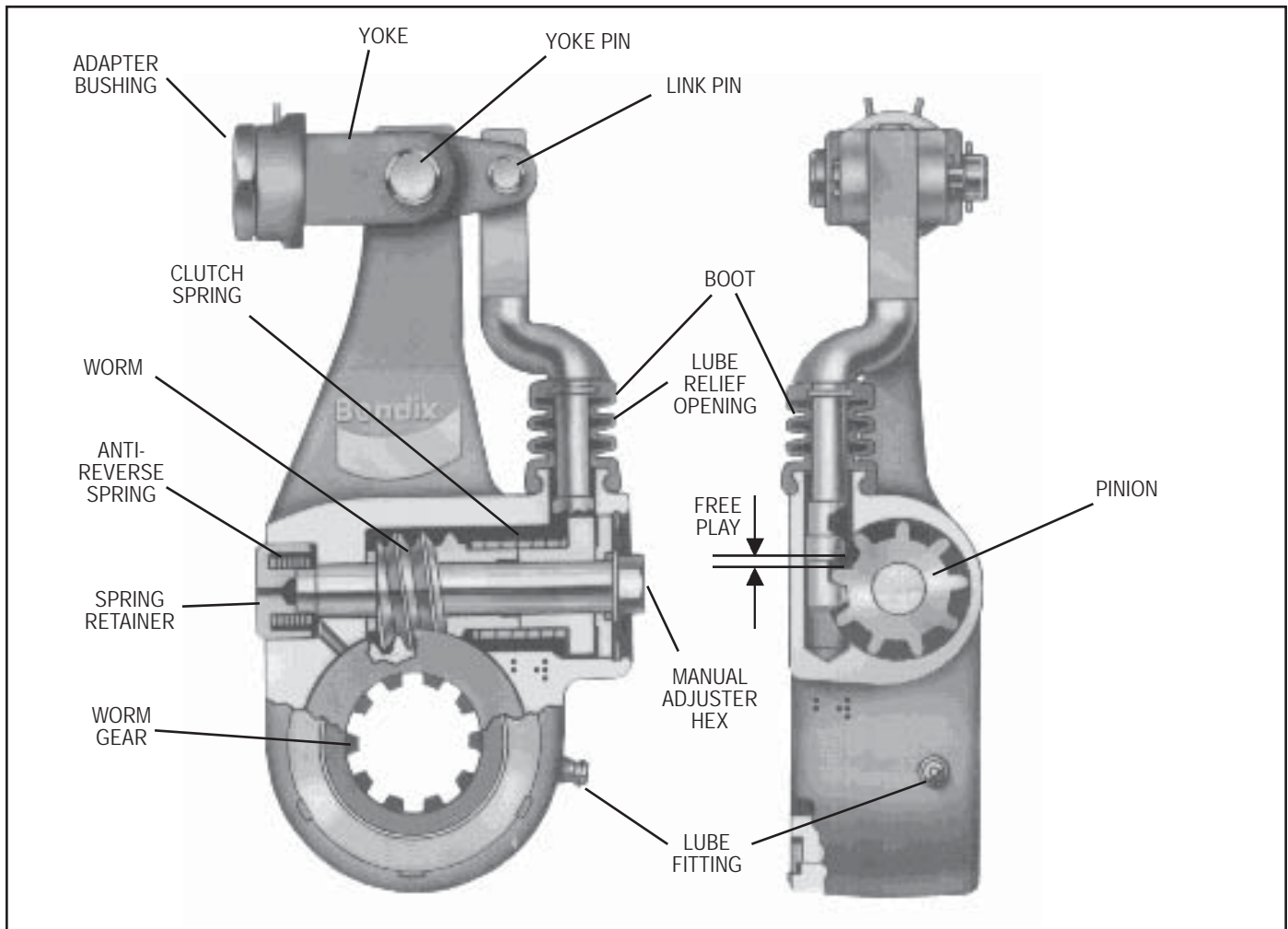

FIGURE 2 - SECTIONAL VIEW OF PROFILE AND END

of the worm. Brake adjustment ceases at this point and further rotation of the ASA-5[®] slack adjuster will cause the pinion and clutch spring to slip. The “free play” between the link teeth and pinion results in a predetermined lining to drum clearance.

BRAKE RELEASE

When the brake application is released, the brake actuator push rod returns the ASA-5[®] slack adjuster to the released position. During release, the ASA-5[®] slack adjuster rotates back toward the actuator causing the brake camshaft to again rotate, but in the opposite direction, and the brake shoes begin to move away from the drum. As the ASA-5[®] slack adjuster rotates back to the release position the yoke again pivots causing the link to be pushed downward into the slack adjuster body. The “free play” between the link teeth and pinion is taken up during the initial part of the release. Continued movement of the ASA-5[®] slack adjuster toward the released position causes the link to rotate the pinion. The anti-reverse spring prevents counterclockwise rotation of the shaft and worm causing the pinion and clutch spring to slip. The gripping action of the anti-reverse spring and slippage of the clutch spring during release is due to the direction of the coil windings of each.

YOKE DESIGNS

ASA-5[®] slack adjusters may be equipped with either of two yoke designs. Both are designed to permit installation or removal of the slack adjuster along with its yoke body and its attached adjusting linkage.

The brake actuator push rod must thread into the adapter a minimum of 1/2 inch and must not extend more than 7/64 inch beyond the other end of the adapter. The yoke adapters (quick connect & easy-on) have either a 1 or 1-1/4 inch hex to allow tightening of the brake actuator push rod jam nut.

EASY-ON YOKE (REFER TO FIGURE 3)

The easy-on yoke assembly consists of an adapter which is threaded internally to match the push rod threads and externally to match female threads in the yoke. A special extended yoke adapter is also available as a separate service item. The extended adapter is 1/2 inch longer than the standard and is primarily intended for use when the existing brake actuator push rod is too short.

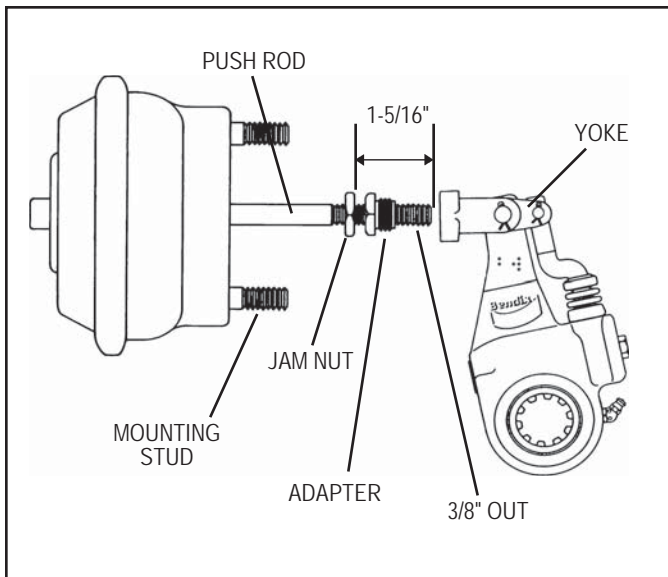

FIGURE 3 - EASY-ON YOKE ASSEMBLY

QUICK-CONNECT YOKE

The adapter bushing in this case is threaded internally to match the push rod, but is designed to slide into the yoke. A retainer ring is used to secure the adapter bushing in the yoke. (Refer to Figure 4.)

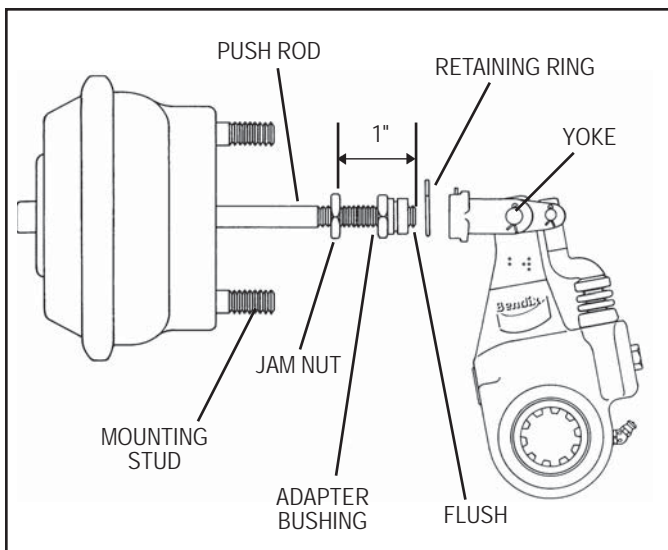

FIGURE 4 - QUICK-CONNECT YOKE ASSEMBLY

GENERAL SAFETY GUIDELINES

WARNING! PLEASE READ AND FOLLOW THESE INSTRUCTIONS TO AVOID PERSONAL INJURY OR DEATH:

When working on or around a vehicle, the following general precautions should be observed **at all times**.

1. Park the vehicle on a level surface, apply the parking brakes, and always block the wheels. Always wear safety glasses.

2. Stop the engine and remove ignition key when working under or around the vehicle. When working in the engine compartment, the engine should be shut off and the ignition key should be removed. Where circumstances require that the engine be in operation, **EXTREME CAUTION** should be used to prevent personal injury resulting from contact with moving, rotating, leaking, heated or electrically charged components.
3. Do not attempt to install, remove, disassemble or assemble a component until you have read and thoroughly understand the recommended procedures. Use only the proper tools and observe all precautions pertaining to use of those tools.
4. If the work is being performed on the vehicle's air brake system, or any auxiliary pressurized air systems, make certain to drain the air pressure from all reservoirs before beginning **ANY** work on the vehicle. If the vehicle is equipped with an AD-IS® air dryer system or a dryer reservoir module, be sure to drain the purge reservoir.
5. Following the vehicle manufacturer's recommended procedures, deactivate the electrical system in a manner that safely removes all electrical power from the vehicle.
6. Never exceed manufacturer's recommended pressures.
7. Never connect or disconnect a hose or line containing pressure; it may whip. Never remove a component or plug unless you are certain all system pressure has been depleted.
8. Use only genuine Bendix® replacement parts, components and kits. Replacement hardware, tubing, hose, fittings, etc. must be of equivalent size, type and strength as original equipment and be designed specifically for such applications and systems.
9. Components with stripped threads or damaged parts should be replaced rather than repaired. Do not attempt repairs requiring machining or welding unless specifically stated and approved by the vehicle and component manufacturer.
10. Prior to returning the vehicle to service, make certain all components and systems are restored to their proper operating condition.
11. For vehicles with Antilock Traction Control (ATC), the ATC function must be disabled (ATC indicator lamp should be ON) prior to performing any vehicle maintenance where one or more wheels on a drive axle are lifted off the ground and moving.

INITIAL INSTALLATION PREPARATION

1. If necessary, carefully remove the manual or automatic slack adjuster currently installed, including the brake chamber yoke assembly.
2. Before mounting the ASA-5® slack adjuster on the camshaft, check the brake chamber push rod length to determine whether shortening or replacement is required. To accomplish this:
 - A. With the brake chamber in the released position, place a square (or equivalent object) so that one edge is parallel to the actuator push rod while the other edge bisects the brake camshaft. Measure the distance from the push rod end to the vertical edge of the square and compare it to the values in Figure 5.
 - B. If the measurement is less than the minimum shown in Figure 5, the brake actuator push rod must be shortened. If the measurement is greater than the maximum values, the brake actuator push rod may require replacement. The extended adapter, available as a separate service part (5/18"-18 pc. no. 297700 and 1/2"-20 pc. no. 297701) may avoid the need to replace the brake actuator push rod. The extended adapter is available for the easy-on yoke assembly only. Note: Installing any other type of push rod extender is not recommended, because these devices may loosen over time and result in an improperly adjusted brake.

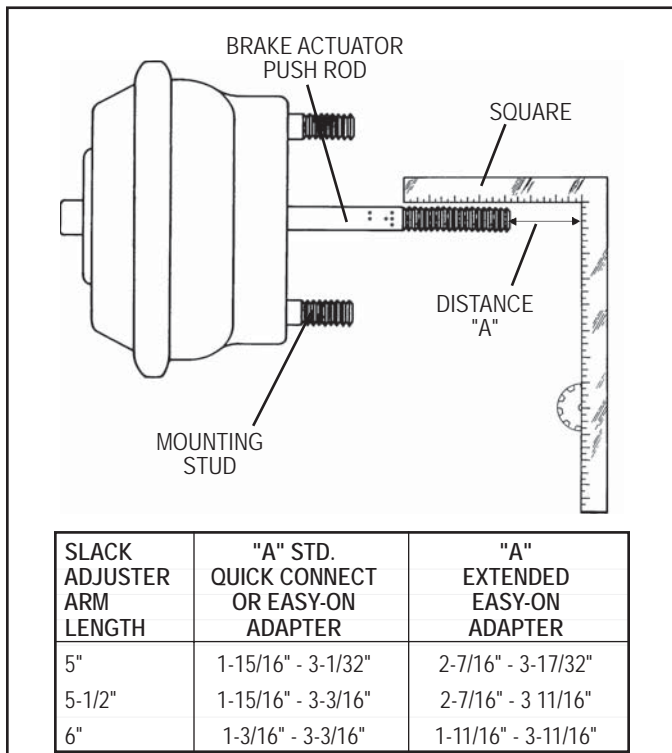

FIGURE 5 - MEASURING THE BRAKE ACTUATOR PUSH ROD

3. Inspect the foundation brake, brake chamber and related components. Make certain the camshaft bushings and seals are not excessively worn. Lubricate the camshaft bushings. Check the brake chamber bracket for cracks and excessive corrosion. The brake actuator push rod should not be loose or bent and the return spring should be firm. Replace parts that are suspect.
4. Wire brush the foundation brake camshaft to loosen contamination and wipe clean. Depending on environmental conditions, an application of anti-seize compound to both the camshaft and worm gear spline may facilitate later slack removal.

INSTALLATION

1. Select the proper ASA-5® slack adjuster.
2. Install the ASA-5® slack adjuster on the brake camshaft.
3. If the ASA-5® slack adjuster has the easy-on yoke (see Figure 3), position the brake actuator push rod jam nut approximately 1-5/16 inches from the end of the brake actuator push rod. Thread the easy-on yoke adapter on the brake actuator push rod until it is approximately 3/8 inch from the end of the brake actuator push rod end. Turn the ASA-5® slack adjuster manual adjustment hex clockwise until the adapter extends into the threaded bore of the yoke approximately 1/8 inch. Thread the adapter into the yoke and tighten to 10 foot pounds.
The installation angle of a properly installed ASA-5® slack adjuster:
 4. If the ASA-5® slack adjuster has the quick connect yoke (see Figure 4), position the brake actuator push rod jam nut approximately 1 inch from the end of the brake actuator push rod. Thread the quick connect adapter bushing on the brake actuator push rod until it is flush

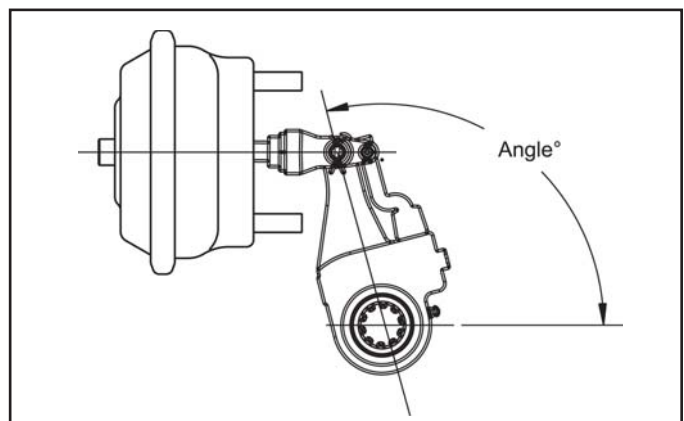

FIGURE 6 - INSTALLATION ANGLE

Slack Adjuster	
Arm Length	Angle
5"	99°-113°
5.5"	98°-111°
6"	90°-109°

with the end of the brake actuator push rod. Install the retaining ring on the adapter bushing, making certain it is in the adapter bushing groove. Turn the ASA-5® slack adjuster manual adjustment hex clockwise until the adapter bushing begins to enter the yoke. Fully compress the retaining ring “legs” and continue turning the ASA-5® slack adjuster manual adjustment hex until the adapter bushing is completely in the yoke. Allow the retaining ring to expand into the corresponding groove in the yoke. Make certain the retaining ring is seated in both the yoke and the adapter bushing groove by manually pulling the ASA-5® slack adjuster arm, attempting to separate the adapter bushing and yoke.

5. Run the brake actuator push rod jam nut down against the adapter or adapter bushing. Hold the adapter or adapter bushing hex with a wrench and tighten the jam nut to 300-400 inch pounds for the 1/2"-20 thread and 400-600 inch pounds for the 5/8"-18 thread.
6. Manually adjust the brakes.

Note: The vehicle brakes should be adjusted using the vehicle or brake manufacturer’s recommendation. If they are not available, the following procedure can be used: Rotate the manual adjustment hex clockwise until the linings are snug against the drum. Turn the adjustment hex counterclockwise 1/2 turn. Pull the actuator push rod to confirm that approximately 1/2 inch of push rod free stroke exists. Apply 85 psi and check that the push rod stroke is below the readjustment limit. If the stroke exceeds the readjustment limit, check the condition of the foundation brake. Refer to *Brake Maintenance Inspection*.

7. Manually uncage the spring brakes before returning the vehicle to service.
8. With the ASA-5® slack adjuster installed, check to ensure clearance requirements with the brake fully released and at the actuator’s maximum stroke. Also consider clearances with the vehicle suspension springs depressed to the jounce bumpers, as well as in rebound.

PREVENTIVE MAINTENANCE

Important: Always review the Bendix Warranty Policy before performing any intrusive maintenance procedures. A warranty may be voided if intrusive maintenance is performed during the warranty period.

No two vehicles operate under identical conditions, as a result, maintenance intervals may vary. Experience is a valuable guide in determining the best maintenance interval for air brake system components. At a minimum, the ASA-5® slack adjuster should be inspected every 3 months or 500 operating hours, whichever comes first, for proper operation. Should the ASA-5® slack adjuster not meet the elements of the operational tests noted in this document, further investigation and service of the adjuster may be required.

Visually check for physical damage such as broken air lines and broken or missing parts.

Every 25,000 miles, or 3 months, or 500 operating hours or at the time of routine vehicle chassis lubrication, whichever occurs first, the following steps should be followed (Also observe any shorter brake adjustment inspections or maintenance intervals specified by the vehicle manufacturer):

1. Lubricate the automatic slack adjuster through the lube fitting with a quality multipurpose chassis lubricant (N.L.G.I. Grade 2).
Lubricate the slack adjuster until clean lubricant flows from the grease relief opening in the boot.
2. Perform the *In Service Inspection* described in this manual.

IN SERVICE INSPECTION

1. Apply and release the vehicle brakes several times while observing the ASA-5® slack adjuster. The ASA-5® slack adjuster and brake actuator should move freely without binding or interference and should return to the full released position. Observe the looseness that exists between the yoke and adapter bushing and the yoke and link pins and their mating parts (yoke, body, link). Replace these parts if looseness appears excessive. Make certain the brake actuator push rod jam nut is tight against the yoke adapter.
2. Inspect the ASA-5® slack adjuster for physical damage paying particular attention to the link, boot and yoke. Inspect for bent, broken, loose or misaligned brake actuator push rods and cracked or damaged brake actuator brackets. Repair or replace any components found to be damaged.

ACTUATOR STROKE TABLE

STANDARD STROKE

Brake Actuator Size	Recommended Maximum Operating Stroke
30	2"
24	1-3/4"
20	1-3/4"
16	1-3/4"
12	1-3/8"

LONG STROKE

Brake Actuator Size	Recommended Maximum Operating Stroke
30LS	2-1/2"
24L	2"
24LS	2-1/2"
20L	2"
16L	2"

3. Measure the brake actuator push rod stroke while making an 80-90 psi service brake application. Actuator push rod strokes should not exceed the values shown in the following actuator stroke tables. The correct

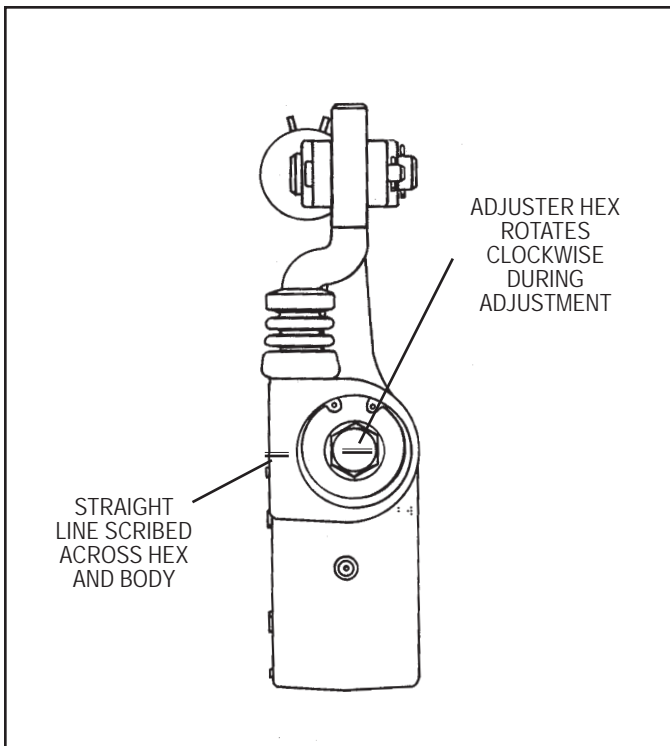

FIGURE 7 - TESTING ADJUSTER MECHANISM

pressure for this test can be achieved as follows: Build the system pressure up to 100 psi reading on the vehicle gauge. Shut the engine off. Fan the brakes to attain a 90-95 psi reading. Make and hold a full brake application while the strokes are checked.

4. The Bendix® *SureStroke™* indicator is also available as a visual stroke indicator. The *SureStroke™* indicator is a metal bracketing system that bolts onto the brake chamber and allows drivers to check the indicator for operating stroke.

IF THE SLACK ADJUSTER DOES NOT AUTOMATICALLY ADJUST THE BRAKES

If the actuator stroke exceeds those shown in the stroke table, inspection of the foundation brake and/or the automatic slack should be performed. Maintenance of the foundation brake may be a factor in the excessive stroke conditions. Inspecting the foundation brake per the *Brake Maintenance Inspection* presented in this manual should determine how much of the long stroke condition is caused by the condition of the foundation brake. The ASA-5® slack adjuster can be tested using the instructions presented in this manual under *Testing the ASA-5® Adjuster Mechanism*. The automatic slack adjuster is not designed to function as a manual adjuster once it is unable to maintain adjustment automatically. Manual adjustment should only be done as a temporary measure to correct brake adjustment in an emergency situation. The routine manual adjustment of an automatic slack adjuster that is still within adjustment limits may shorten its service life. Automatic slack adjusters should not be manually adjusted in an effort to correct excessive pushrod stroke, because this condition indicates

that a problem exists with the automatic adjuster, with the installation of the adjuster, or with related foundation brake components, which manual adjustment will not fix. Replacement of the automatic slack adjuster or other foundation brake components may be necessary. Consult with the manufacturer's troubleshooting guidelines to find and fix the problem.

WARNING: Manual adjustment of automatic slack adjusters is a dangerous practice that could have serious consequences, because it can give the operator a false sense of security about the effectiveness of the brakes, which are likely to go out of adjustment again soon. Do not make manual adjustments of an automatic slack adjuster once it can no longer automatically adjust the brakes. Manual adjustment DOES NOT fix the underlying wheel end adjustment again. As soon as possible, have the vehicle inspected by a qualified technician or consult the manufacturer's troubleshooting guidelines to find and fix the problem.

TESTING THE ASA-5® ADJUSTER MECHANISM

The following test can be made to determine if the ASA-5® adjuster mechanism is functioning properly.

1. With the brakes released and the vehicle wheels blocked, de-adjust the brakes by rotating the manual adjustment hex counterclockwise approximately 1/2 to 1 revolution.

Note: Considerable torque is required to rotate the manual adjustment hex counterclockwise and should be considered normal. The required torque may be as high as 70 foot pounds.

2. Using a straight edge, scribe a line across the manual adjustment hex head and slack adjuster body. (Refer to Figure 7).
3. Apply and COMPLETELY RELEASE the service brakes several times while observing the manual adjustment hex and the scribed line. The ASA-5® slack adjuster manual adjustment hex should rotate clockwise during the application and remain stationary during release. No counterclockwise rotation of the hex should be observed. The amount of clockwise rotation (adjustment) will decrease progressively as the brake nears proper adjustment. If the ASA-5® slack adjuster fails to perform as described, it will be necessary to repair or replace it.
4. Manually readjust the ASA-5® slack adjuster being tested before returning the vehicle to service. (See section *Installation*, Step 6)

Note: While it is possible to use the automatic adjustment feature of the ASA-5® slack adjuster to bring the brake back into adjustment, it will require numerous applications

and COMPLETE RELEASES (the number of applications depends on how much the slack was de-adjusted).

BRAKE MAINTENANCE INSPECTION

Note: Make certain the vehicle has been prepared according to the instructions under the heading *GENERAL SAFETY GUIDELINES*.

The following test can be used to inspect the maintenance condition of the foundation brake and to determine how much of the chamber stroke is caused by the condition of the foundation brake.

1. Always chock the wheels to keep vehicle from moving.
2. Raise the axle so the wheel can be rotated.
3. Adjust the slack adjuster to produce light brake drag with wheel rotation.
4. Apply the brake to 80-90 psi and measure the stroke (See Item 3 of *In Service Inspection* for pressure tips).
5. If the stroke significantly exceeds the values shown in the chart, the brake may be out of the norm and brake maintenance may be required.

AL Factor	15"x4" Front Brake	16.5"x7" Tractor, Truck or Bus Brake	16.5"x7" Trailer Brake
12 X 5.0"	1/2"	N/A	N/A
12 X 5.5"	1/2"	N/A	N/A
16 X 5.0"	5/8"	1/2"	N/A
16 X 5.5"	3/4"	1/2"	N/A
16 X 6.0"	7/8"	5/8"	N/A
20 X 5.0"	5/8"	1/2"	3/8"
20 X 5.5"	3/4"	5/8"	1/2"
20 X 6.0"	7/8"	3/4"	5/8"
24 X 5.0"	N/A	5/8"	1/2"
24 X 5.5"	N/A	5/8"	5/8"
24 X 6.0"	N/A	3/4"	5/8"
30 X 5.0"	N/A	3/4"	5/8"
30 X 5.5"	N/A	7/8"	3/4"
30 X 6.0"	N/A	1"	7/8"

ASA-5® SLACK ADJUSTER REMOVAL

Note: Make certain the vehicle has been prepared according to the instructions under the heading *GENERAL SAFETY GUIDELINES*.

1. If the ASA-5® slack adjuster is equipped with the easy-on yoke assembly illustrated in Figure 3:
 - A. Loosen the brake actuator push rod jam nut and run it back on the brake actuator push rod approximately 5/8 inch.
 - B. Loosen the easy-on yoke adapter and run it back on the brake actuator push rod until it is free of the yoke.

- C. Rotate the manual adjustment hex counterclockwise until the ASA-5® slack adjuster is clear of the brake actuator push rod.

Note: Considerably more torque is required to rotate the manual adjustment hex counterclockwise than is necessary to rotate it clockwise. The torque may be as high as 70 foot pounds.

2. If the ASA-5® slack adjuster is equipped with the quick-connect yoke assembly illustrated in Figure 4:
 - A. Rotate the ASA-5® slack adjuster's manual adjustment hex counterclockwise until the brake actuator push rod just begins to move out of the actuator.
 - B. Pinch the legs of the retaining ring together and pull the ASA-5® slack adjuster away from the brake actuator push rod until the adapter bushing is free of the yoke. Remove the retaining ring from the adapter bushing.
 - C. Rotate the manual adjustment hex counterclockwise until the ASA-5® slack adjuster is clear of the brake actuator push rod.
3. Remove the ASA-5® slack adjuster from the camshaft of the foundation brake by removing the retaining clip and any spacers or washers that may be present.

DISASSEMBLY

GENERAL

A reasonable level of cleanliness should be observed when working on the ASA-5® slack adjuster. Clean the exterior before disassembly.

The following disassembly and assembly procedure is presented for reference purposes and presupposes that a rebuild or repair of the ASA-5® slack adjuster is being undertaken. Several replacement parts and maintenance kits are available which do not require full disassembly. The instructions provided with these parts and kits should be followed in lieu of the instructions presented here.

1. Clamp the ASA-5® slack adjuster ARM in a bench vise. Do not clamp across the portion of the body that contains the adjuster assembly or worm gear. Using a wire brush, thoroughly clean the exterior of the slack adjuster paying particular attention to the area around the manual adjustment hex and its retaining ring. Wipe all loose contaminants away before proceeding.
2. Remove the cotter pins and washers from the yoke pin and link pin.
3. Remove the yoke pin and link pin and separate the yoke from the ASA-5® slack adjuster.
4. If the ASA-5® slack adjuster has a yoke pin bushing, press it out of the slack adjuster arm.
5. No further disassembly of the ASA-5® slack adjuster is permitted.

CLEANING AND INSPECTION

1. Inspect the worm gear camshaft splines for damage. If damaged, replace the ASA-5® slack adjuster.
2. Clean and inspect the yoke pin and link pin holes in the yoke, adjuster link and slack adjuster body. The holes should be visually round with no perceptible “egg shaping.” A new yoke pin and link pin can be used to make this inspection. If this condition is noted, the affected part must be replaced.
3. Clean out the retaining ring grooves in the yoke.

REASSEMBLY

1. If the ASA-5® slack adjuster uses a yoke pin bushing, press it into the slack adjuster arm.
2. Depending on environmental conditions an application of anti-seize compound to both the yoke and link pins may facilitate later removal. Install the yoke and secure it to the ASA-5® slack adjuster body and link using the yoke pin and link pin. Install washers and cotter pins in the yoke pin and link pin, and secure each. Bend each leg of the cotter pins to a minimum of 25 degrees, creating an included angle of at least 50 degrees between the legs.
3. Lubricate the automatic slack adjuster through the lube fitting with a quality multipurpose chassis lubricant (N.L.G.I. Grade 2). Lubricate the slack adjuster until clean lubricant flows from the grease relief opening in the boot.

RETROFITTING THE ASA-5® SLACK ADJUSTER

PREPARATION

The Bendix® ASA-5® automatic slack adjuster can replace a manual slack or competitive automatic slack adjuster provided some considerations are kept in mind:

1. Excessive duty cycles, high application pressures and brake force compounding can result in reduced slack adjuster durability.
2. Determine that the AL factor of the vehicle to be retrofitted is 195 or less. To determine the AL factor multiply the slack adjuster arm length (from the center of the cam spline to the center of the yoke pin hole in use) times the brake chamber size. Example: a type 30 brake chamber connected to a 6 inch arm slack adjuster, $A = 30$ square inches, $L = 6$ inches; therefore, $30 \times 6 = 180$, AL factor.
3. Make sure the foundation brake components are in good condition. Excessive drum out-of roundness will result in excessive lining wear. See the *In Service Inspection* section contained in this manual.
4. In order to select the proper slack adjuster, choose an ASA-5® slack adjuster with the same arm length, spline size, push rod thread size and offset as the slack adjuster it is replacing.
5. When retrofitting the Bendix® ASA-5® slack adjuster, make certain to read the instructions packaged with all service replacement ASA-5® slack adjusters.

ASA-5® SLACK ADJUSTER TROUBLESHOOTING CHART

SYMPTOMS	CAUSE	REMEDY
<p>1. Brake Actuator stroke is too long.</p> <p>WARNING: Automatic slack adjusters should not be manually adjusted in an effort to correct excessive push rod stroke, because this condition indicates that a problem exists with the automatic adjuster, with the installation of the adjuster, or with related foundation brake components, which manual adjustment will not fix.</p>	A. Loose actuator push rod jam nut.	A. Reposition components and torque to specification.
	B. Excessive clearance between adapter/ adapter bushing and yoke due to wear.	B. Replace damaged or worn parts.
	C. Excessive clearance between components: yoke pin—yoke link pin—link yoke pin—body.	C. Replace worn parts.
	D. Damaged (worn) splines on slack or camshaft.	D. Replace damaged parts.
	E. Weak or broken brake actuator return springs. Weak or broken brake shoe return spring.	E. Replace weak or broken springs.
	F. Worn or broken foundation brake components, including camshaft bushings, brake chamber bracket, etc.	F. Repair or replace as required per <i>In Service Inspection</i> .
	G. ASA-5® adjuster mechanism not functioning.	G. Lubricate, test adjuster mechanism, conduct in service inspection, repair components as necessary, replace.
	H. Brake drum—worn, excessively machined, bell-mouthed, excessive thermal expansion.	H. Replace or repair as required.
	I. Damaged ASA-5® slack adjuster.	I. Replace component(s) or slack adjuster.
	J. ASA-5® slack adjuster improperly installed.	J. Correct installation position.

ASA-5® SLACK ADJUSTER TROUBLESHOOTING CHART (Continued)

SYMPTOMS	CAUSE	REMEDY
2. Brakes dragging—apparent over-adjustment of brakes.	A. ASA-5® slack adjuster improperly installed. Too close to actuator: brakes can't fully release.	A. Correct the ASA-5® slack adjuster installation.
	B. Loose actuator push rod jam nut.	B. Reposition components and torque to specification.
	C. Spring brakes not fully retracting.	C. Check spring brake release air pressure and repair or replace air valving as necessary. Repair or replace spring brake.
	D. Broken foundation brake components, including camshaft bushings.	D. Repair or replace as required per <i>In Service Inspection</i> .
	E. Vehicle brake torque imbalance. (More work done by some brakes than others, thermal expansion of drums).	E. Check other brakes to ensure they are working. Check air pressure balance and threshold pressure (refer to Bendix publication BW-1555). Check driver braking habits, e.g. use of trailer control valve. Use same friction material on all axles.
	F. Brake drum out-of-round, excessive thermal expansion.	F. Replace or repair as required.
	G. Air system malfunction, not exhausting completely.	G. Inspect and correct.
	H. New lining swells during break-in.	H. Back-off adjustment until brakes are free.

